



# Red•Dot® Deck Grommet™ PRO – Power Where You Need It!

## Concealed Receptacle Provides a Safe and Aesthetic Solution for Outdoor Raised Deck Applications



Closed While In Use



Open by Releasing Latch



Simply Plug-In Appliance

### Eliminates the Safety Hazard of Cords Plugged in to Outdoor Post or Wall Mounted Outlets!

Now you can provide power for small appliances on outdoor raised decks safely and conveniently with the new Red•Dot® Deck Grommet™ PRO. When not in use, the receptacle remains concealed beneath the deck board, showing only a stylish non-metallic cover. The Deck Grommet™ PRO is a versatile power solution for protecting outdoor receptacles mounted on a raised deck surface.

Deck Grommet™ PRO complies with National Electrical Code® (NEC) requirements for installing receptacles in wet locations. The NEMA 3R solution provides protection against falling rain, sleet, snow, and external ice formation. The Deck Grommet™ PRO is the first device to pass the agency testing requirements specifically developed for receptacles installed in a raised deck for “While-In-Use” application.

### Features & Benefits:

- Complies with NEC® Section 406.9 (B) (1) and 590.4 (D) (2) for unattended in-use plugs in wet locations and “Extra-Duty” outlet box hoods — now required for any installation.
- Ideal for outdoor living spaces and light commercial raised deck applications. Examples: Residential recreation areas, Outdoor restaurants, Hospitality recreation areas, etc.
- Use for easy access to power for small appliances, lighting, water fountain pumps, etc.
- Eliminates the potential safety hazard of power cords draping along the deck surface.
- The power outlet remains recessed below the raised deck whether in use or not.
- Duplex adapter plate provided for use with conventional TR/WR duplex receptacle.

### Installation Highlights:

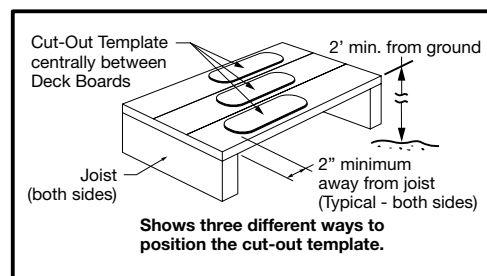

Refer to product instruction sheet for actual installation procedures.

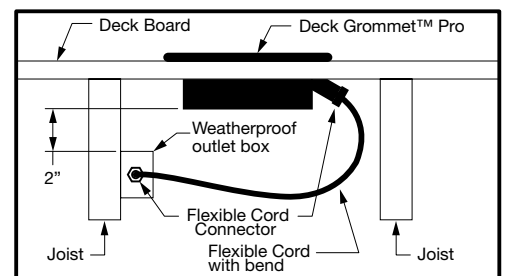

**Installation Highlights:**

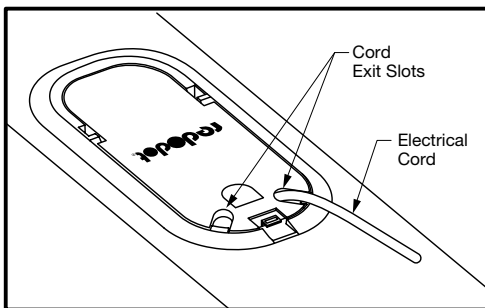
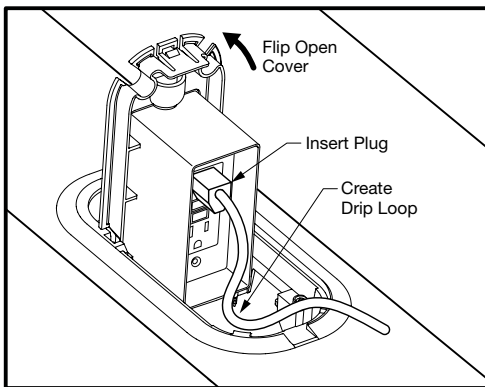
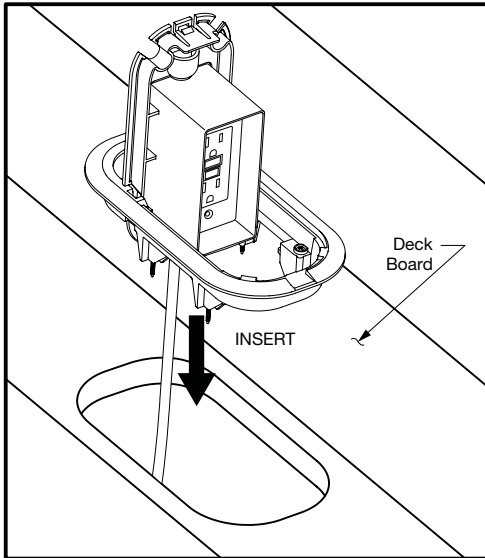
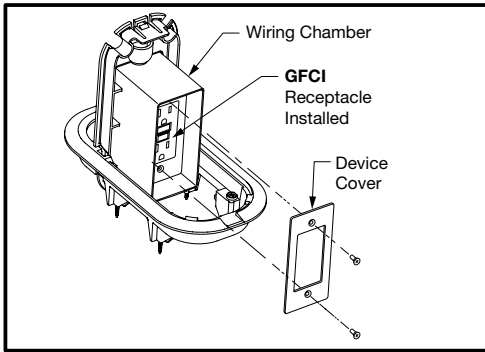

**Meets new UL and NEC requirements  
For While-In-Use Outdoor Receptacles**

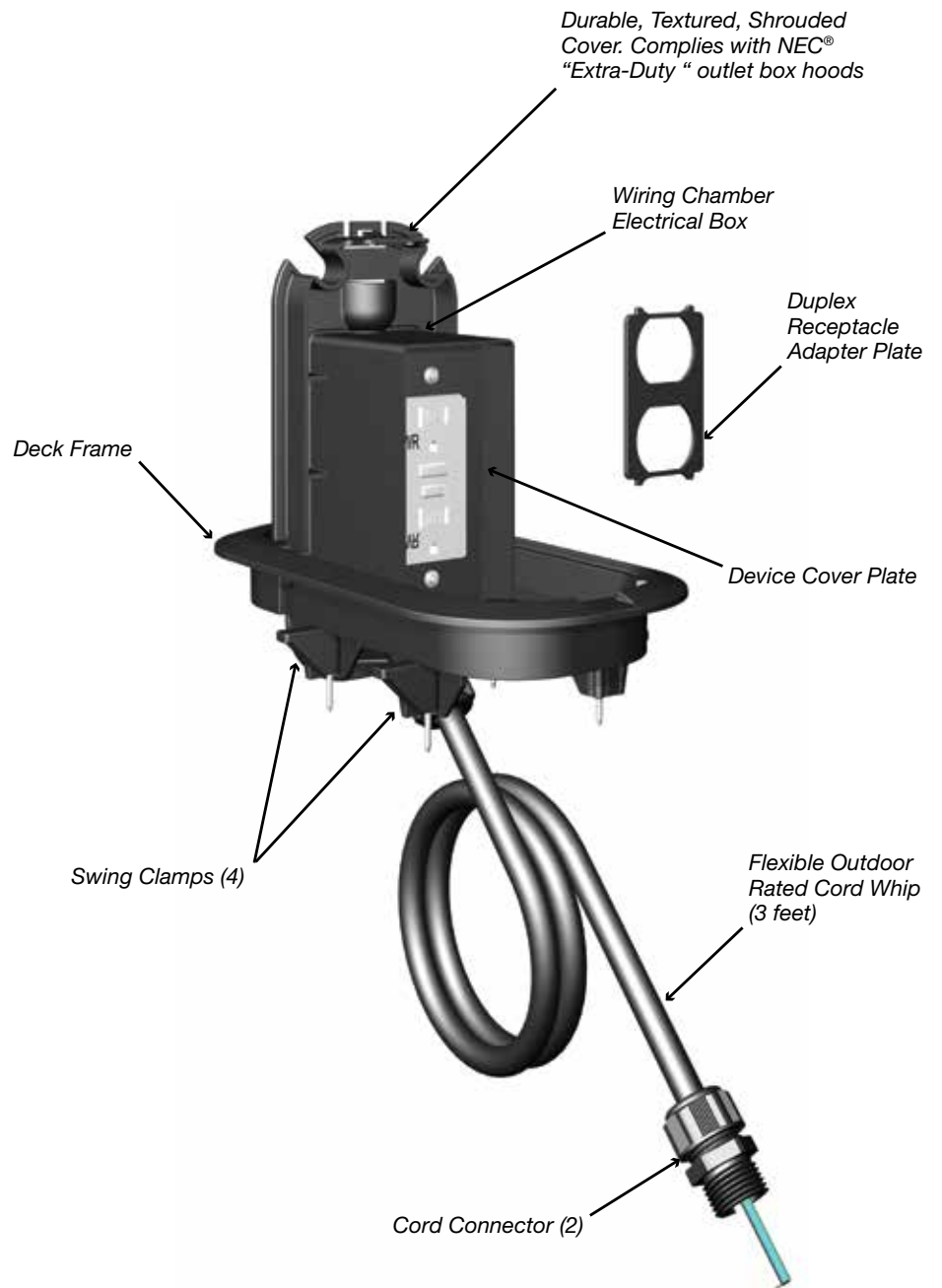

**Receptacle remains concealed from outdoor weather conditions when in use or not in use**

Refer to product instruction sheet for actual installation procedures.

## Red•Dot® Deck Grommet™ Pro Includes:

### (Parts List)

- A. (1) Deck Grommet
- B. (1) Cut-Out Template
- C. (1) Device Cover Plate
- D. (1) Duplex Receptacle Adapter
- E. (2) Flexivle Cord Connector
- F. (1) 3-Wire Flexible Cord Type SJOOW  
(3 feet, one and stripped, one end unstripped)

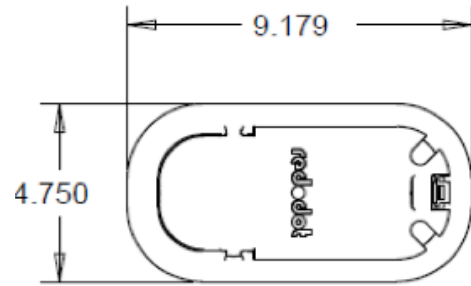
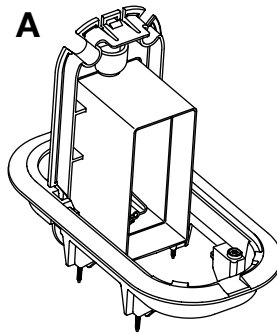

Top View

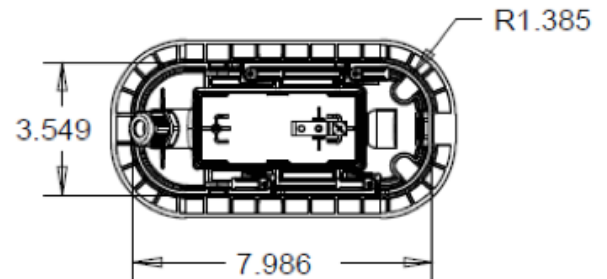
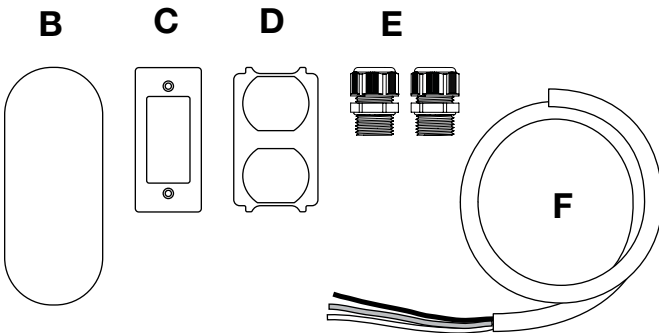

Bottom View

### Required Items

(Not Included)

Weatherproof outlet box and cover  
(Red•Dot® Cat. Nos. IH3-1 (Box) & CCB (Cover) recommended)

GFCI or Standard Duplex Receptacle - Weather  
Resistant (WR) and Tamper Resistant (TR)

### Specifications

Hole Cutout Size: 3.6" x 8.0" (Cut-Out  
Template Included)

Product Dimensions: 4.75" x 9.18"

Hard Surface Cord Whip: 12/3 AWG, SJOOW,  
Rated 105°C 300V, Whip  
Length 3 feet

Listings/Compliances:



## Red Dot® Deck Grommet PRO

Cat. Number	Description	Color	Std. Pkg. Qty.	UPC Number
DKG-PRO	Deck Grommet™ PRO, Tray Pack	Black	4	042269-00750

Please ask your Thomas & Betts sales representative for a complete catalog of quality Thomas & Betts electrical products or visit us at [www.tnb.com](http://www.tnb.com). For customer service, call 1-800-816-7809. For technical questions, call 1-888-862-3289.

© 2015 Thomas & Betts Corporation. All rights reserved. Printed in the U.S.A.  
1/15/4M GM7362

**Thomas & Betts Corporation**  
Electrical Division  
8155 T&B Boulevard  
Memphis, TN 38125  
901-252-5000  
[www.tnb.com](http://www.tnb.com)

**Thomas & Betts**  
A Member of the ABB Group