

Main

Range of product	Preventa Safety detection
Accessory / separate part designation	Laser alignment tool
Accessory / separate part type	Laser
Accessory / separate part category	Installation accessories
Accessory / separate part destination	Safety light curtain type 2 Safety light curtain type 4

Complementary

Product weight	1.76 lb(US) (0.8 kg)
----------------	----------------------

Environment

Offer Sustainability

Green Premium product	Green Premium product
Compliant - since 1425 - Schneider Electric declaration of conformity	Compliant - since 1425 - Schneider Electric declaration of conformity
Reference not containing SVHC above the threshold	Reference not containing SVHC above the threshold
Available	Available
Available	Available

Dimensions

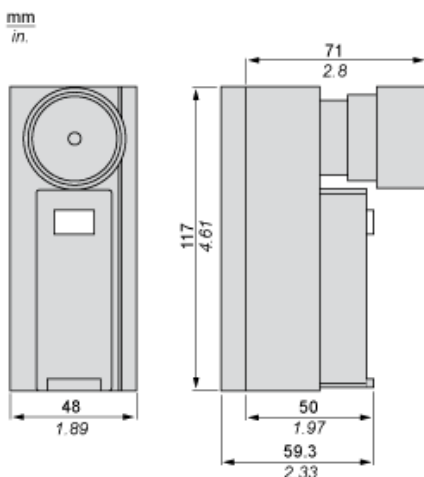

Mounting and Clearance

Laser Alignment Device

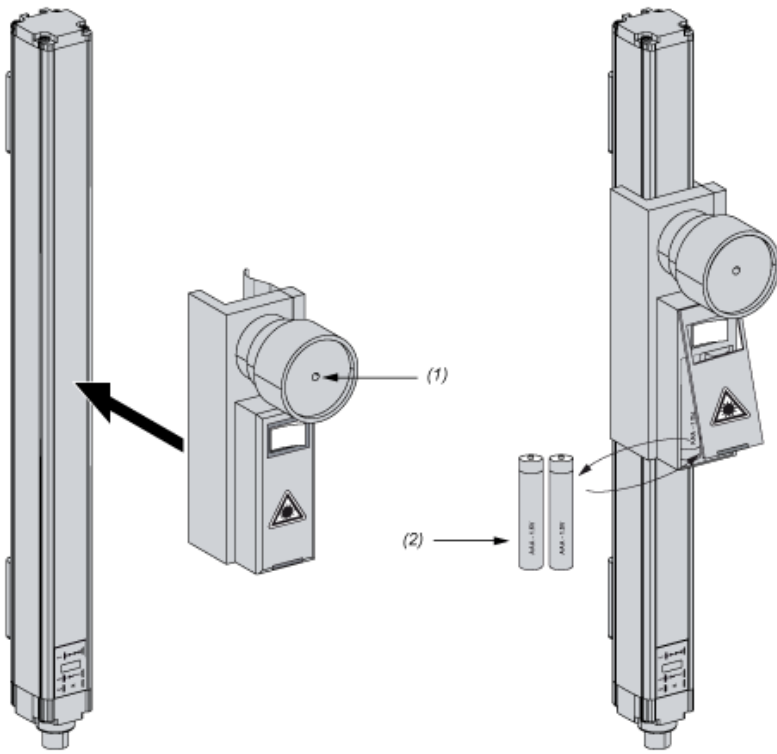

- (1) Position of the laser beam
- (2) 2 AAA batteries (not part of package)