

ASSEMBLY VIEW



	NAME	DATE
DRAWN	SD	15/05/2006
CHECKED	KM	15/05/2006
APPROVED	KM	15/05/2006
MATERIAL	-	
TOLERANCE	-	
Drawing No.	-	2775/a

TITEL- cast connector T C 2/0

SCALE- N.T.S. FINISH- -----

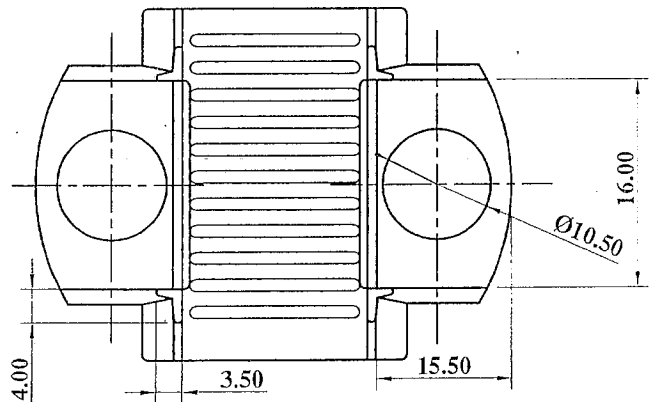
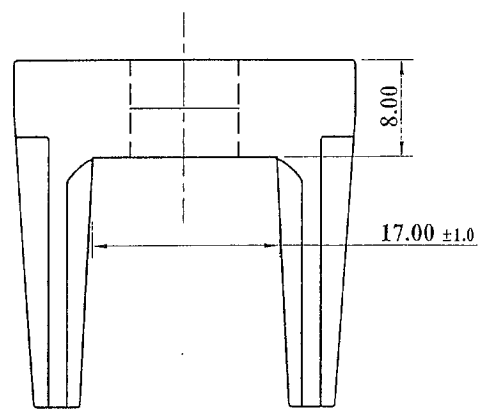
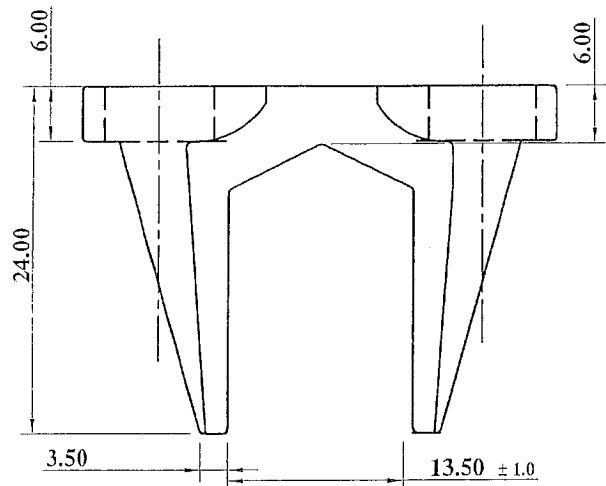
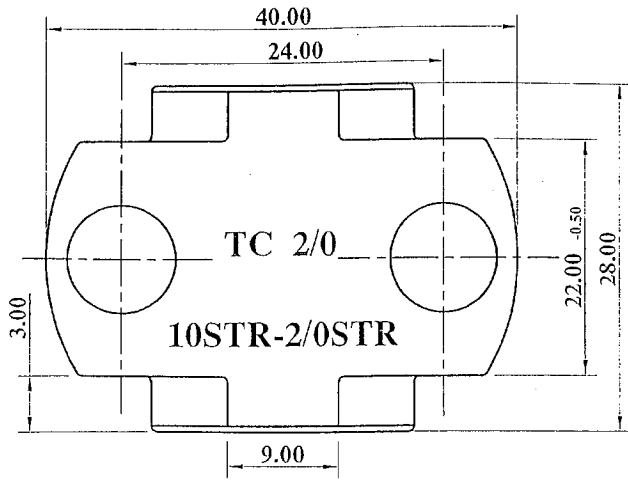

	NAME	DATE
DRAWN	SD	15/05/2006
CHECKED	KM	15/05/2006
APPROVED	KM	15/05/2006
MATERIAL-		C-956
TOLERANCE-		+/- 0.50

SCALE-N.T.S. | TITEL- Body TC 2/0

TREATMENT- Natural

ALL DIMENSION ARE IN M.M.

DRAWING NO.- 2775/b

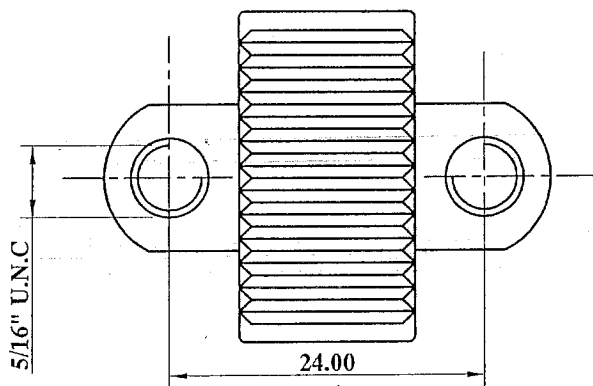
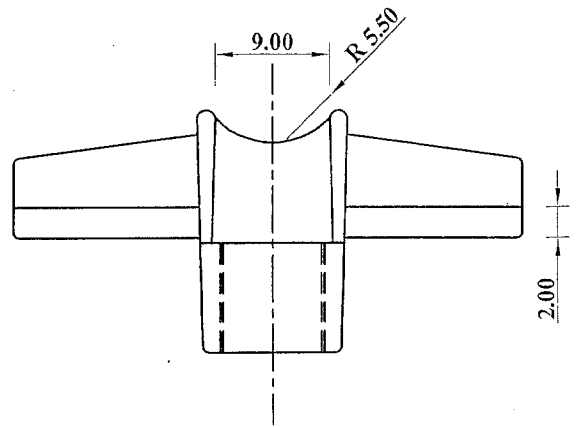
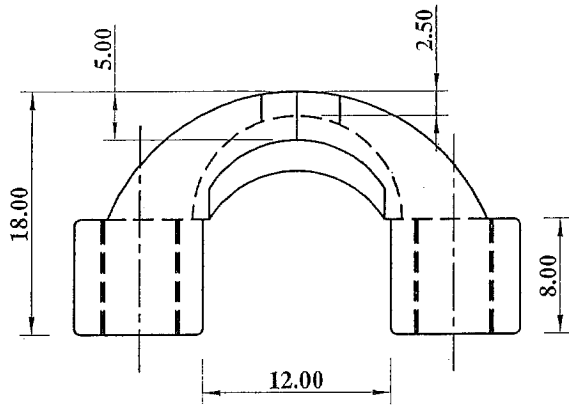
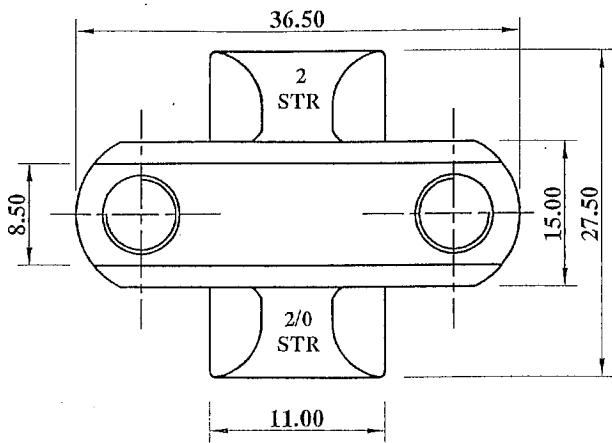

	NAME	DATE
DRAWN	SD	15/05/2006
CHECKED	KM	15/05/2006
APPROVED	KM	15/05/2006
MATERIAL-	C-956	
TOLERANCE-	+/- 0.50	

SCALE-N.T.S. TITEL- Base TC 2/0

DRAWING NO. 2775/c

TREATMENT- Natural

ALL DIMENSION ARE IN M.M.

SILICON BOLT "A"

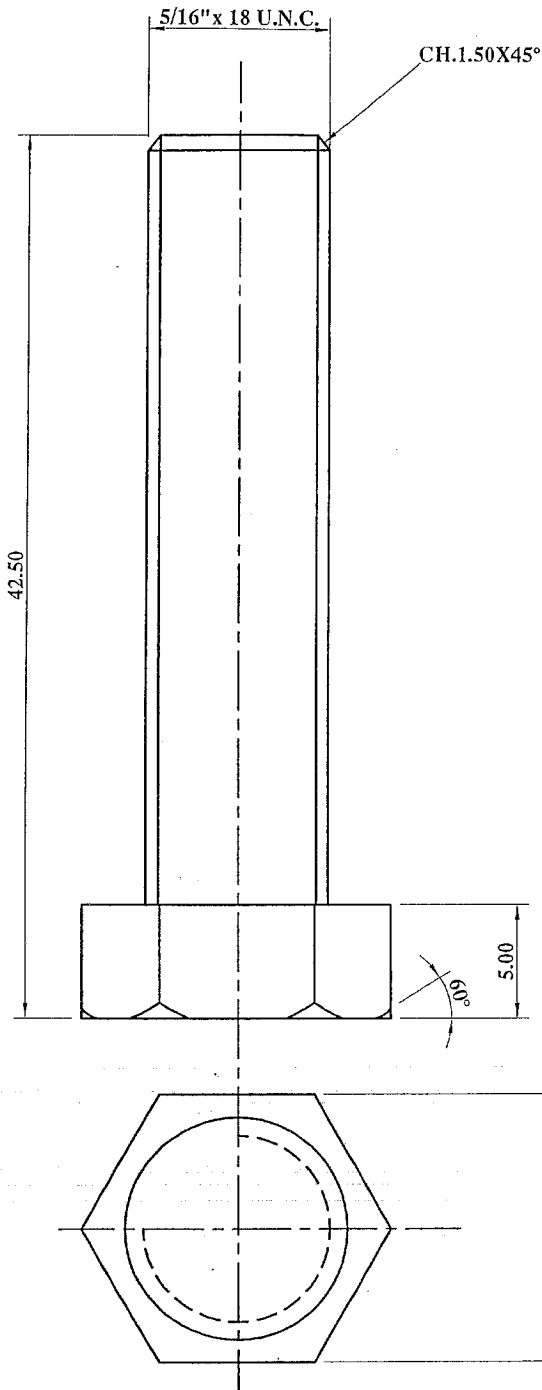

WASHER "B"

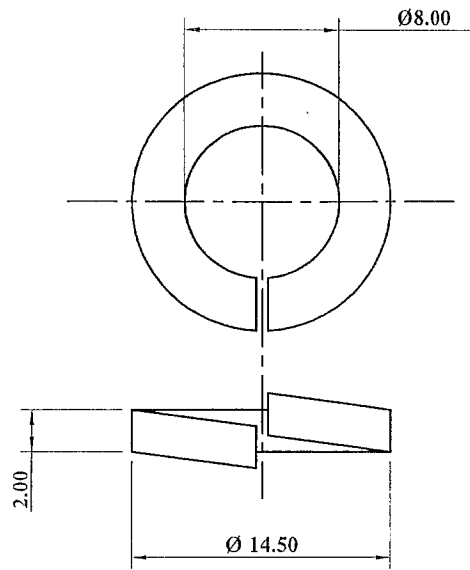

RUBBER WASHER "C"

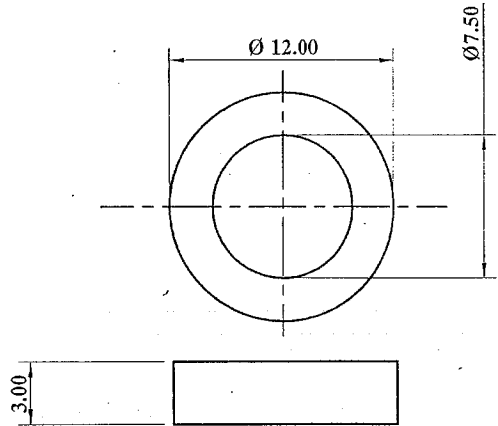

ITEM	MATERIAL
A	SILICON BRONZE
B	S.S 304
C	NEOPRENE



	NAME	DATE
DRAWN	SD	15/05/2006
CHECKED	KM	15/05/2006
APPROVED	KM	15/05/2006
MATERIAL- As Per Chart		
TOLERANCE- +/- 0.25		

SCALE-N.T.S. TITEL- Accessories TC 2/0

TREATMENT- NATURAL

ALL DIMENSION ARE IN M.M.

DRAWING NO. 2775/d