

LAMP SUPPORT CLIPS

2G11 Base



COMPACT FLUORESCENT

Plastic and Stainless Steel Lamp Support Clips

Leviton offers a selection of lamp support clips for 2G11 lampholders. Clips are available in UV stable clear polycarbonate for horizontal or vertical mounting or in stainless steel with UV stable clear polycarbonate base for horizontal mounting only. The stainless steel clip is offered in short and tall versions.

Standard pack: bulk

Cat. No. 23452-V: Clear Vertical Lamp Support Clip*

Cat. No. 23452-H: Clear Horizontal Lamp Support Clip*

Cat. No. 23452-MTS: Stainless Steel Horizontal Lamp Support Clip, Short Version

Cat. No. 23452-MTL: Stainless Steel Horizontal Lamp Support Clip, Tall Version

* NOTE: Leviton strongly recommends replacing support clips 23452-V and 23452-H during lamp replacement.



Cat. No. 23452-H



Cat. No. 23452-V



Cat. No. 23452-MTS



Cat. No. 23452-MTL

SECTION B

Cat. No. 23452-V

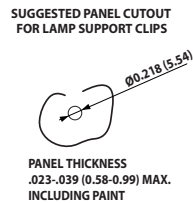
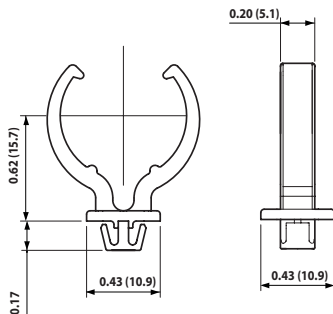

Cat. No. 23452-H

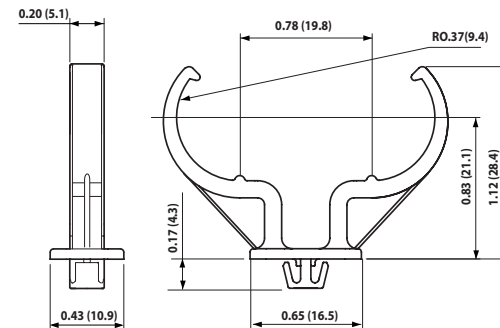

Vertical Lamp Support Clip

Horizontal Lamp Support Clip

Cat. Nos. 23452-MTS, 23452-MTL

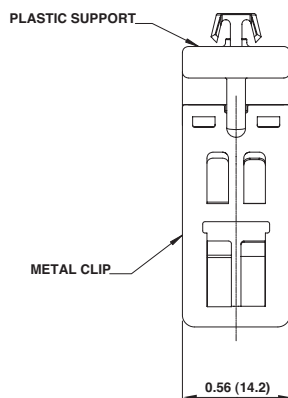

Cat. No. 23452-MTS

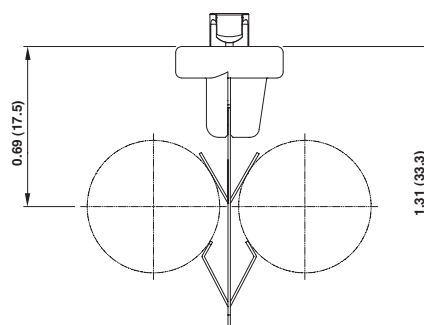

Horizontal Lamp Support Clip, Short

Cat. No. 23452-MTL

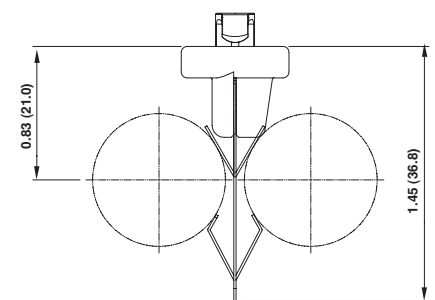

Horizontal Lamp Support Clip, Tall