

Commercial Grade

Lamp Support Clips for Long Twin Tube 2G11 Base Fluorescent Lampholders

Specifications and Features

- Choice of quality lamp support clips in a variety of configurations for long twin tube lamps with 2G11 base
- UV stable clear polycarbonate clips for vertical or horizontal mounting
- Stainless steel clips with UV stable clear polycarbonate base for horizontal mounting only; short or tall versions
- Plastic clips for slide-on or screw-mount

PLASTIC AND STAINLESS STEEL LAMP SUPPORT CLIPS

Description	Cat. No.
Plastic Lamp Support Clip, Slide-On	23452-A*
Plastic Lamp Support Clip, Screw Mount	23452-B*
Horizontal Snap-In Lamp Support Clip for 13454, 23454, 13455 and 23455. UV-Stable, Clear Polycarbonate	23452-H*
Vertical Snap-In Lamp Support Clip for 13453 and 23453. UV-Stable, Clear Polycarbonate	23452-V*
Stainless Steel Horizontal Lamp Support Clip, Short Version	23452-MTS
Stainless Steel Horizontal Lamp Support Clip, Tall Version	23452-MTL

*NOTE: Leviton strongly recommends replacing support clips 23452-A, 23452-B, 23452-V and 23452-H during lamp replacement.



23452-H



23452-V



23452-MTS



23452-MTL

DIMENSIONS

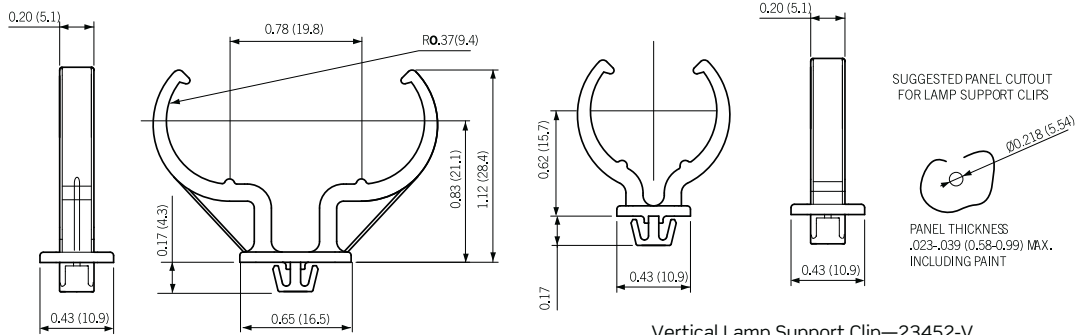

Horizontal Lamp Support Clip—23452-H

Vertical Lamp Support Clip—23452-V

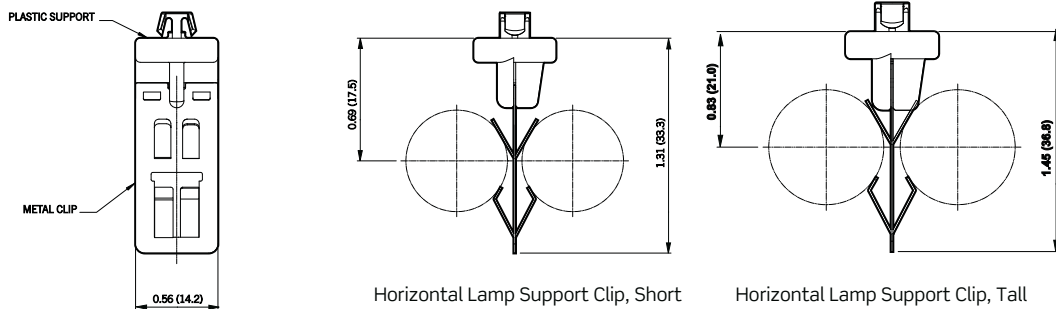

Horizontal Lamp Support Clips
23452-MTS, 234452-MTL

Horizontal Lamp Support Clip, Short
23452-MTS

Horizontal Lamp Support Clip, Tall
23452-MTL