

Pow-R-Way III Upward Elbow

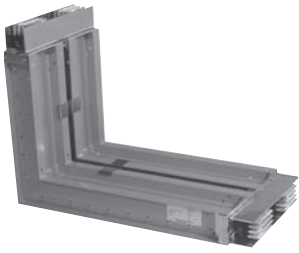

6.1 Pow-R-Way III

Pow-R-Way III Busway

Product Description	V2-T6-2
Features, Benefits and Functions	V2-T6-12
Standards and Certifications	V2-T6-13
Product Support	V2-T6-13
Catalog Number Selection	V2-T6-14
Product Selection	V2-T6-15
Technical Data and Specifications	V2-T6-20
Dimensions	V2-T6-26

6.2 Pow-R-Way

Pow-R-Way Busway

Product Description	V2-T6-32
Standards and Certifications	V2-T6-32
Product Selection	V2-T6-33
Accessories	V2-T6-35
Technical Data and Specifications	V2-T6-35

6.3 100A Busway

100A Busway

Product Description	V2-T6-37
Application Description	V2-T6-37
Product Selection	V2-T6-37
Options and Accessories	V2-T6-38
Technical Data and Specifications	V2-T6-39



Learn
Online

6.1

Low Voltage Busway

Pow-R-Way III

Pow-R-Way III Busway

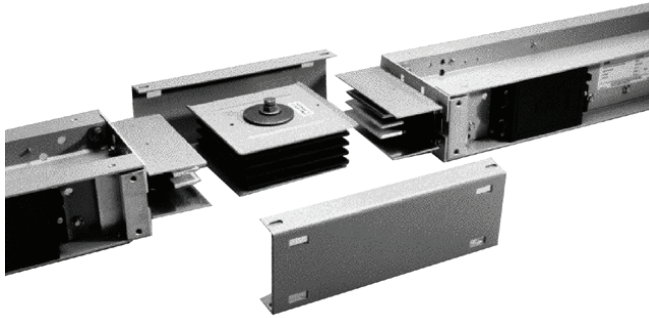

6

Contents

Description	Page
Pow-R-Way III Busway	
Features, Benefits and Functions	V2-T6-12
Standards and Certifications	V2-T6-13
Product Support	V2-T6-13
Catalog Number Selection	V2-T6-14
Product Selection	V2-T6-15
Technical Data and Specifications	V2-T6-20
Dimensions	V2-T6-26

Pow-R-Way III Busway

Product Description

Superior Housing Design and a True Sandwich Design Maximize Busway Performance

Eaton's Pow-R-Way III® is constructed with a lightweight and durable, two-piece, aluminum-extruded housing. The non-ventilated housing design excludes potential points of penetration by moisture or dust. Busbars for plug-in applications have full-sized conductor tabs welded by a fully automated state-of-the-art welding process. This design extends the contact surfaces outside of the busway housing and into the plug-in outlet. The benefits of the true sandwich design for both plug-in and feeder busway include improved coordination and heat dissipation, better bracing and the elimination of the "chimney effect."

Epoxy Insulation Provides Exceptional Performance

The phase and neutral bars are insulated with Class B, 130°C, epoxy insulation applied by an automated fluidized bed process. This application insulates the conductors in a precise and controlled manner to ensure smooth, continuous, high quality protection. Following the epoxy insulation process, all contact surfaces are silver-plated to provide an extremely durable connection. Tin-plating is also an option.



Indoor Joint Assembly

Pow-R-Way III Bridge Joint Reduces Installation Time and Provides Flexibility for Future Modifications

Pow-R-Way III joint connections are made with the rugged Pow-R-Bridge package. A Pow-R-Bridge is installed on each section of busway prior to shipment. Job site connections are made quickly by releasing the bridge joint bolt, moving the next section into place, and retightening the bolt. Torque-indicating, double-headed bolts with fall-away instruction tags are provided to ensure that proper installation torque is achieved. The Pow-R-Bridge provides an adjustment in section length of up to ±0.5-inch (12.7 mm) at each joint.



Bridge Joint Assembly

Pow-R-Way III Offers Grounding and Neutral Options to Meet Every Customer Preference and Need

The aluminum housing is UL listed as a 50% integral ground path and is provided as a standard, economical ground system. A 50% internal ground bar is also available. In certain industrial applications, a ground path greater than 50% may be required. Pow-R-Way III can solve this problem in a cost-efficient manner through combining the 50% integral housing ground with the 50% internal ground. To meet the growing demand for grounding isolation, Pow-R-Way III also offers a 50% isolated ground bar. When customers are concerned about harmonics and overheating generated by nonlinear loads, Pow-R-Way III provides a solution through a fully rated 200% capacity neutral bar.



Joint End

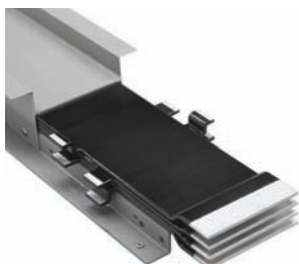

Cut-Away Section of Plug-In Busway

A Space-Saving Innovation— The Corner Joint Elbow

The Pow-R-Way III corner joint combines the features of the Pow-R-Bridge with reduced elbow leg lengths. Due to its compact design, the corner joint allows for layouts that provide optimum use of space and increases available plug-in openings.

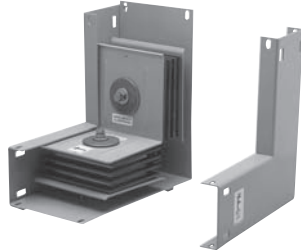

Upward Corner Joint

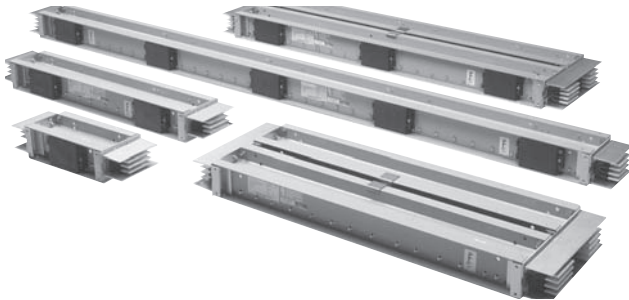

Straight Lengths

A Complete Line of Fittings for Indoor and Outdoor Applications

Pow-R-Way III offers an extensive range of fittings to meet every application need. Flanges, elbows, end cable tap boxes and end closers are used in basic busway routing. For more complex layouts, combination elbows and offsets can be used along with transformer throats, vault flanges, reducers and expansion joints.



End Cable Tap Box

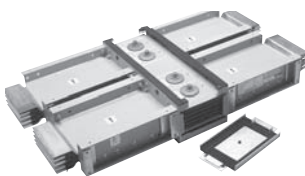

Outdoor Joint Assembly



Standard Switchboard Flange



Plug-In Unit

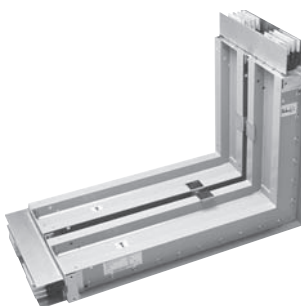

Upward Elbow

Enhanced Bus Plug Design Facilitates Installation and Improves Safety

Pow-R-Way III plug-in protective devices are available in circuit breaker and fusible switch designs. Standard features include: oversized enclosures, extended ground and neutral bars, line side barriers, bus plug alignment pin, busway interlock and improved clamp and guides.

Advanced bus plugs provide protection, communication and coordination capabilities using the Visor™ Series (SPD), Energy Sentinel™, Digitrip™ IQ OPTIM™, Advantage™ motor control components and receptacle plugs.

High 6-Cycle Short-Circuit Ratings Optimize Coordination Between Busway and Power Equipment and Meet High Quality Standards

All ratings of Pow-R-Way III have been tested to 6-cycle standards and have achieved a minimum rating of 85 kA and a maximum rating of 200 kA rms symmetrical.



**Typical Busway Installation
(Torque Indicating Bolt)**



Final Busway Assembly



Rearward Corner Joint Assembly

6.1

Low Voltage Busway

Pow-R-Way III

6

General Information

- Determine the total footage, all fittings and accessories for entire busway run. Price the total footage by type and system requirements. Round footage up to the nearest foot. Add the fabrication charge for the fittings. Add any additional accessories required for the total price of the busway run
- See NEC 364.11 for Reducer Application
- Fusible reducers are 600V maximum; fuses are not included

Transformer Connections

- Transformer tap bus extensions do not include drilling or lugs
- Transformer throats include flexible connectors

Commercial Metering Connections

- For use with 33MM, 37MM and 37SS meter stack modules; order separately
- Main breaker units include circuit breaker and trip units
- 1200A or greater main devices must be center fed when installing 800A residential meter sockets and 1200A commercial meter sockets
- Spacer kit 3MMBSK may be required when stacks are mounted on right-hand side in EUSERC areas
- Class T fuse clips only; fuses not included
- Compatible with indoor corner elbow accessory 3MMEB12 and 3MMEB16
- In-line metering PTO with no overcurrent protection should only be used with six meter sockets/tenant main circuit breakers or less, or applied per local code

Plug-In

- Straight sections of plug-in busway are available in 2 ft (0.6m) increments from 2 ft (0.6m) minimum to 10 ft (3m) maximum. Pow-R-Bridge joint is included

Sprinkler-Proof Plug-In

- For sprinkler-proof plug-in, multiply the plug-in price by 1.15 and use outdoor pricing for the feeder busway

Feeder

- Straight sections of feeder busway are available in 1/8-inch (3.2 mm) increments from 16 inches (406 mm) minimum to 10 ft (3m) maximum. Pow-R-Bridge joint is included. Busway must carry at least a 50% load in all outdoor applications

Hangers/Pow-R-Bridge

- The busway price includes one horizontal hanger per 10 ft (3m) of busway and one Pow-R-Bridge joint per connection. All vertical hangers and any additional horizontal hangers should be added to the total price

Ground

- A 50% integral housing ground is provided as standard. The housing ground can be used in combination with the internal ground or the isolated ground to achieve a 100% ground rating

Standard and Flush Flanges

Flanges provide a direct connection to low voltage switchgear, switchboards, motor control centers and other apparatus. Cutout dimensions and drilling plans are provided with the customer drawings, and it is the responsibility of the switchgear manufacturer to provide the opening, flange drillings, connecting hardware and bus risers in their equipment. For proper coordination between busway and other equipment, detailed drawings, including switchgear orientation, must accompany the order. A standard flange can be supplied to the left or right of a section, as required. A flush flange is used when the busway must lay close to the top of a switchboard. The edge of the busway is 1.25 of the switchboard.

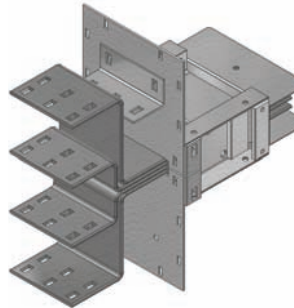
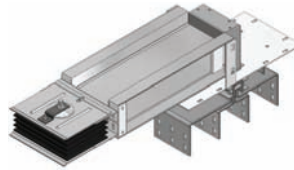

Elbow Flanges

An elbow flange is a combination of a standard elbow and a standard flange fabricated into a single fitting. Elbow flanges are typically used when the minimum leg lengths for either the standard elbow or the standard flange cannot be maintained.

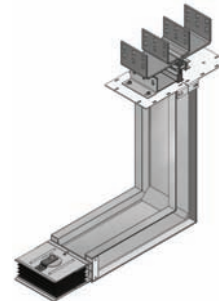
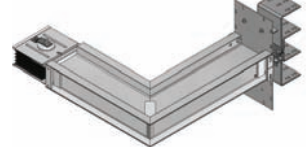
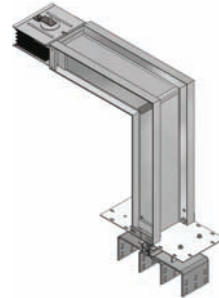

Traditional Indoor and Outdoor Elbows

Elbows are used to make 90° changes in the direction of busway runs. The four types that are available are forward, rearward, upward and downward.



Corner Joint Elbows

The Pow-R-Way III corner joint elbow can be installed in areas where a traditional 90° turn could never have been accomplished before.

Pow-R-Way III corner joint elbows can solve any serious pathway problem and contribute to successful layouts with minimal space requirements. The corner joint elbow is UL listed for indoor applications only and is also certified for seismic withstand capability to worst-case, Zone 4 levels.

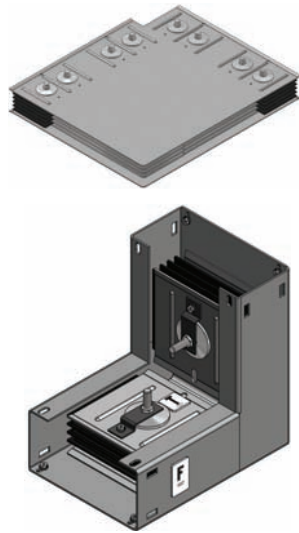

For Indoor Use Only

Special Angle Elbows

Special angle elbows are traditional elbows that allow the direction of the busway runs to change at angles greater than 90°. They allow easy routing through non-traditional corridors. The four types offered are forward, rearward, upward and downward.



Tees

A tee is a busway fitting suitable for connection in three directions.

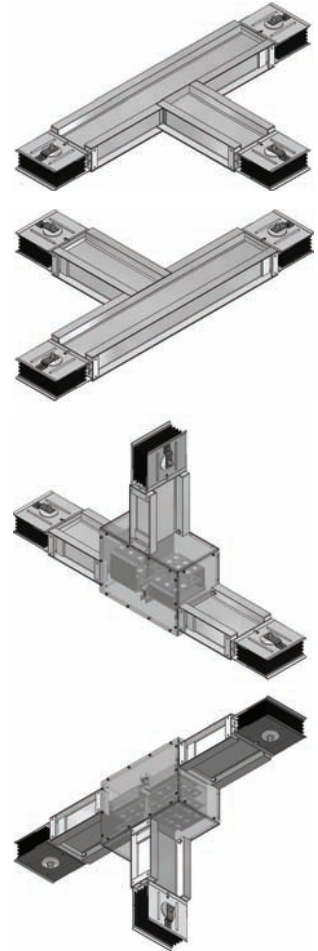

6.1

Low Voltage Busway

Pow-R-Way III

6

Crosses

A cross is a busway fitting suitable for connection in four directions. It is applied when a bus run must branch off in three directions, all in the same plane.

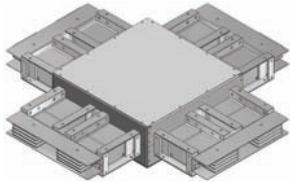

End Cable Tap Box

End cable tap boxes are used to feed a run of busway with cable and conduit or where loads served by busway are connected without the need for overcurrent protection.

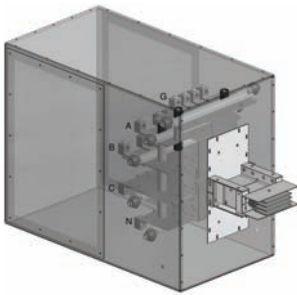

Center Cable Tap Box

Center cable tap boxes are used to center feed a run of busway with cable and conduit or where loads served by the busway are connected without the need for overcurrent protection.

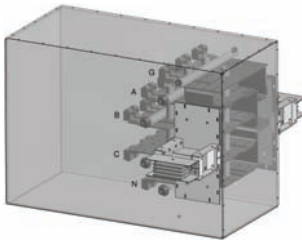

Weatherheads

Weatherheads are used for service entrance connections to busway.

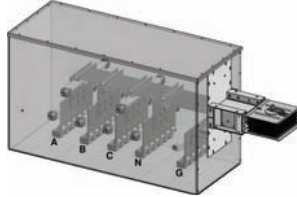

Vault Flanges

Vault flanges are used to enter a utility vault for termination to the utility transformer. Each vault flange is custom designed to meet each specific utility specification. Vault flanges may look similar to those shown in figure below.

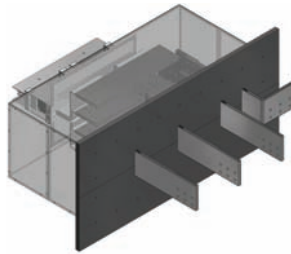

Expansion Joints

Expansion joints accommodate the expansion and contraction of busbars with respect to the enclosure. They compensate for the difference in the coefficient of expansion of the aluminum housing and the copper or aluminum busbars. Expansion joints must be used wherever a run of busway crosses an expansion joint of a building. They should also be installed in the center of extremely long straight runs of busway; one every 300 ft (91m) for copper or one every 225 ft (68m) for aluminum.

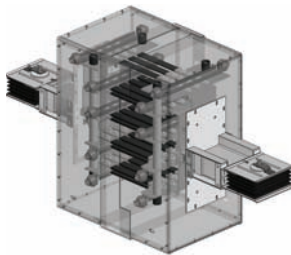

Phase Transpositions

Phase transposition fittings are used in applications where a phase rotation is needed due to a change in phasing from the source equipment to the load equipment. Both 90° and 180° rotations are possible. In each case, all conductors are rotated.

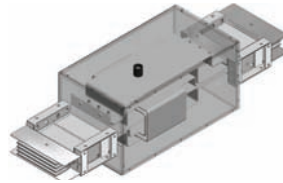

Non-Protected Reducers

Non-protected reducers are used to reduce the ampacity of the busway without overcurrent devices. Per NEC Section 364.11, for industrial applications, no overcurrent protection is required where the busway is reduced in size, provided the length of the smaller busway does not extend more than 50 ft (15.2m) and has a current rating of at least one-third of the first upstream overcurrent device.

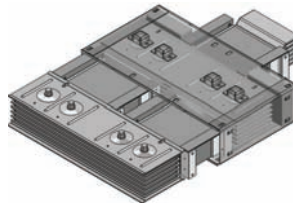

Protected Reducers

Protected reducers are used to reduce the ampacity of busway using either a circuit breaker or a fused, non-automatic circuit breaker overprotection device. Both serve as a disconnecting means. The line side of the cubicle is connected to the higher rated busway and the load side is connected to the lower (reduced) rated busway.

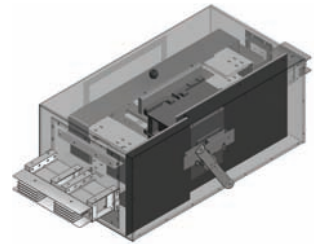

Transformer Throat Connections

A transformer throat is used when making connections to a liquid-filled substation transformer. All transformer throat connections include flexible connectors between the transformer low voltage spades and Pow-R-Way III busbars. For transformers with drilled flanges, the busway will bolt to the transformer throat instead of using a sealing ring.

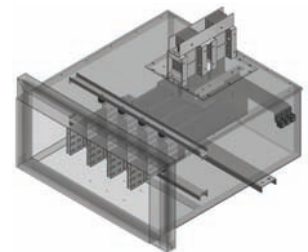

Transformer Flange Connections

Transformer flange connections are used when making a connection to a dry-type substation transformer. Transformer flange connections include flexible connectors between the transformer low voltage spades and the Pow-R-Way III flange busbars.

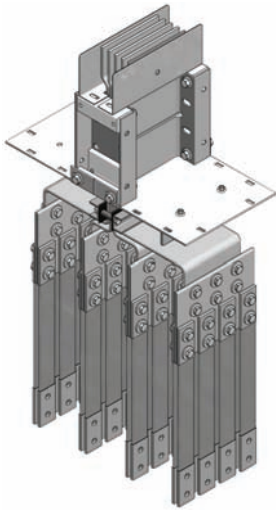

Three-Phase Transformer Taps

Three-phase transformer taps are used when making connections to a three-phase transformer. The bus extensions do not include drilling or lugs.



Single-Phase Transformer Taps

Single-phase transformer taps arrangements are used for connections to three single-phase transformers. The bus extensions do not include drilling or lugs.

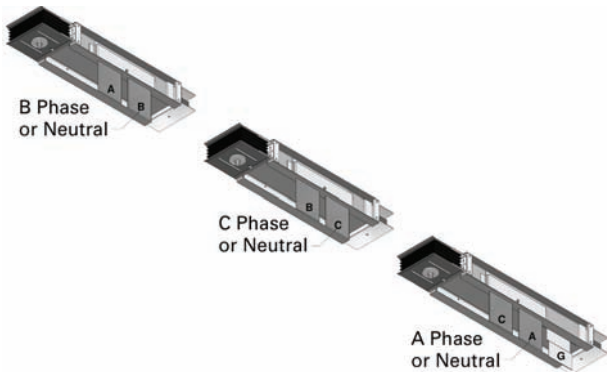

In-Line Power Takeoff

Main Circuit Breaker PTO

The in-line main circuit breaker PTO shown in figure to the left is available with trip ratings from 300A up to 1200A; using L-, M- and N-Frame circuit breakers. This device is indoor rated and may be sprinkler-proofed upon request.

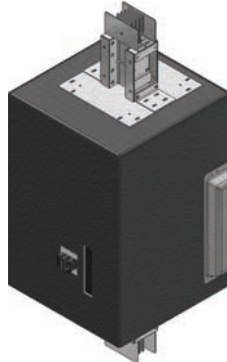

Unprotected PTO

The in-line PTO with no main device shown in figure to the left comes with 1200A horizontal cross bus as standard. This device is intended for use with six or fewer meter sockets, or as local code permits.

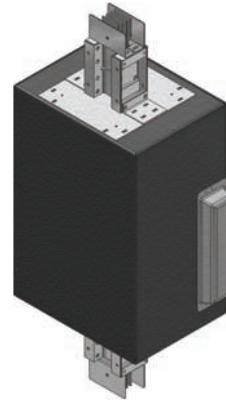

Main Fusible Switch PTO

The in-line main fusible switch PTO shown in figure to the left is available with 400, 600 and 800A switches; using Class "T" fuses. This device is indoor rated only. The switch handle is mounted in front, eliminating interference with the meter sockets and the need for spacers between the main device and the meter stack. It comes with a hinged door, giving easy access to the fuses mounted below the main switch.

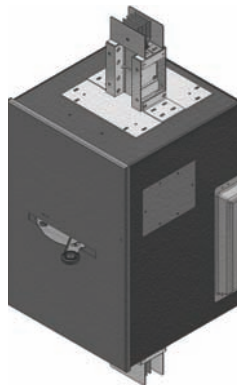

Offsets

An offset is used to avoid obstacles and to conform to the building's structure. It is two elbows fabricated into a single fitting for use where space restrictions prohibit the use of two standard 90° elbows.

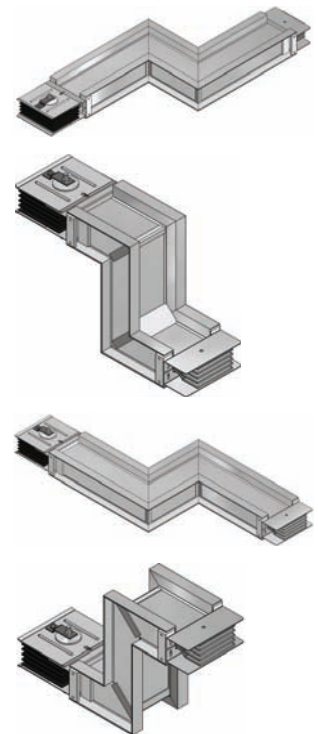

6.1

Low Voltage Busway

Pow-R-Way III

6

Pow-R-Way III Adapters

A complete line of adapters are available to enable the user to add to existing old-line Westinghouse® or obsolete Cutler-Hammer® bus runs with the Pow-R-Way III design. The specific Westinghouse product lines are low impedance busway, current-limiting busway, Pow-R-Way and Pow-R-Way II. The obsolete Cutler-Hammer designs are CP2, CP3 and CP4 Safetybus.

The adapters allow the incorporation of present-day technologies, available in Pow-R-Way III plug-in units, into existing busway systems. State-of-the-art features such as energy monitoring, transient voltage surge suppression and coordination/communication capabilities can all be added to existing distribution systems without having to upgrade and replace entire runs of busway.

Special adapters to competitive busway products are also available. Please contact the Greenwood factory for information.

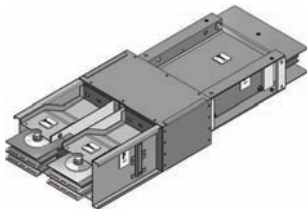

Power Where You Need it!

As a leader in providing quality, robust, cutting-edge electrical distribution equipment, Eaton understands the importance of providing usable power access in a variety of applications. Eaton's Pow-R-Way III busway continues to offer electrical distribution solutions that are flexible and without limitations, and are energy efficient, saving time and money.

Pow-R-Way III Receptacle Plug-In Units

Eaton now offers a full line of receptacle plug-in units for use on Pow-R-Way III busway. Pow-R-Way III receptacle plug-in units come fully assembled and wired, reducing installation time. They are UL listed and offer a complementary line of accessories. Eaton's unique design makes them the most flexible receptacle units in the industry.

Data Centers—Data racks continue to process more information at higher speeds with constantly changing demands. Pow-R-Way III receptacle plugs offer the highest ampere ratings in the industry. Busway and receptacle plugs above the data racks provide faster installation, faster connectivity, easier rack changes and upgrades, and will run cooler than traditional cable methods.

Retail—As retail environments change meeting customer demands, Pow-R-Way III busway and receptacle plugs help make floor layout and display changes easier. Receptacle plugs allow for easy power access, eliminating costly conduit and cable work.

Schools and Laboratories

Pow-R-Way III receptacle plugs offer safe power access for instrumentation and other lab equipment at the point of use.

Machine Shops

Pow-R-Way III busway and receptacle plugs offer quick power connection for shop equipment and make it easy to change shop layouts as demands change.

Light Industrial

Pow-R-Way III busway and receptacle plugs help make manufacturing and assembly lines more flexible. Receptacle plugs bring easy power access for tools and equipment being used on the lines.

For application and layout assistance, and for additional information, please contact your local Eaton sales office or Eaton authorized distributor.

Fused Duplex Receptacle Plug-In Unit

These units allow you to quickly add standard receptacle power and come with the following features:

- Two fix-mounted NEMA 5-20R or L5-20R duplex receptacles
- Fuse protection for each duplex receptacle
- 120V maximum, single-phase



Fix-Mounted Duplex Receptacle

Single Receptacle Plug-In Unit

These units are configured to order based upon the type and size of receptacle ordered, and offer the following features:

- One single or duplex receptacle. Straight blade or twist lock, 5–30A
- 240V maximum, single-phase
- Type CH single-pole or two-pole circuit breaker protection
- Receptacles can be fix-mounted or cord-mounted
- Cord lengths are 1–25 feet in 1-foot increments

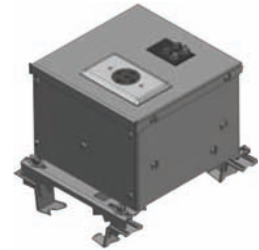

Fix-Mounted Single Receptacle

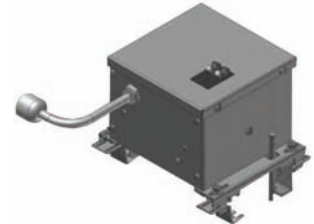

Cord-Mounted Single Receptacle

Quad Receptacle Plug-In Unit

These units are configured to order based upon the quantity, type and size of receptacles ordered. Any combination of receptacles can be ordered and offer the following features:

- Two to four receptacles. Any combination and size of standard NEMA configured receptacles
- 240V maximum, three-phase
- Type CH single-pole, two-pole or three-pole circuit breaker protection
- Receptacles can be fix-mounted or cord-mounted
- Cord lengths are 1–25 feet in 1-foot increments



Fix-Mounted Quad Receptacle

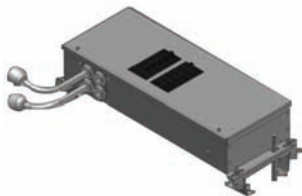

Cord-Mounted Quad Receptacle

SPD Plug-In Devices

The Pow-R-Way III plug-in device product offering includes a surge protective device (SPD) that is ideal for busway fed distribution systems. A transient voltage is a random, high-energy, short duration electrical anomaly. These high-energy surges can disrupt, damage or destroy sensitive microprocessor-based equipment. Eaton has developed the SPD family of products to ensure that quality power is supplied to commercial, industrial, medical and institutional facilities.

The SPD not only protects against externally created impulse transients such as lightning, utility capacitor switching and disturbances emitted by adjacent facilities, but it also provides needed protection against internal transients. This type of transient is generated within a facility's own distribution system. Sources of internally generated or ringwave transients are imaging, equipment, variable frequency drives, lighting dimmers, arc welders, and the switching on and off of electrical distribution equipment. It is estimated that more than 80% of surge disturbances are actually caused by internal transients.

The SPD also filters repetitive electrical line noise (EMI/RFI), which is defined as any unwanted electrical signal that produces undesirable effects in the circuits of sensitive electronic equipment or disturbances that are two times peak voltage. The suppression of AC transients is accomplished through the use of metal oxide varistors (MOVs) that provide a low impedance path to divert surges away from loads. Electrical line noise and ringing transients are eliminated by adding filtering capacitors to the suppression device.

Not all SPD units on the market have filtering capabilities. The benefits of combining SPD and filtering are reduced MOV stress, resulting in a longer life cycle, lower let-through voltage, better noise attenuation levels and increased reliability.

Without protection devices, electronic-based loads and microprocessors are not provided with the noise- and disturbance-free power that they require. Because microprocessors are now common in those facilities, specifiers must ensure that the AC power supply is properly filtered. Significant performance advantages are achieved by integrating SPD filters into busway systems. Because the SPD unit is directly connected to the busway it is able to minimize let-through voltage and to isolate critical loads that are fed from a protected busway run. Due to the integrated design, the SPD bus plug saves the user-needed wall space and greatly reduces the installed project cost. The SPD bus plug is furnished with a breaker disconnect.



SPD Bus Plug

IQ Energy Sentinel Bus Plugs

The IQ Energy Sentinel is a UL listed microprocessor-based metering module capable of communicating energy usage and demand values over Eaton's PowerNet™ power monitoring network. These innovative submetering devices are designed to mount-directly to Series C® molded-case breakers through 400A and are available for universal mounting through 2500A.

It offers a centralized alternative to individually mounted wattmeters, watt-hour meters and watt-demand meters. Key advantages include unmatched savings in space, lower installation costs, and the capability to communicate data readings in a variety of ways. IQ Energy Sentinels with built-in CTs and communication capability have the added benefit of overall system accuracy. The Energy Sentinel mounts on the load side of Eaton F-, J- and K-Frame breakers within the bus plug enclosure. The Energy Sentinel is also available for fusible plug-in units, which use external CTs within the plug-in enclosure.

Submetering application examples for the Energy Sentinel include energy monitoring and demand management, energy cost analysis/allocation and tenant or interdepartmental billing.

To accomplish the communication system, the customer must provide a twisted pair communication cable in 1/2-inch (12.7 mm) conduit connecting the IQ Energy Sentinel to an Eaton Central Energy Display (CED) or a customer PC to display and collect the information.

The IQ Energy Sentinel offers the user full energy monitoring capability in a compact, cost-effective module ideally suited to busway application.

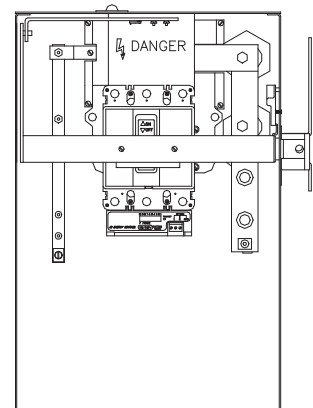

6.1

Low Voltage Busway

Pow-R-Way III

Ground Detector/Neutralizer Bus Plug

In rare cases, busbars in a busway system pick up static electricity. In order to discharge this potential, a neutralizer and a ground detector bus plug is available. The unit has three 18,000 ohm resistors connected between the busbars and the ground. Static electricity is discharged through these resistors.

A neon lamp is wired in series with the busbar and part of the resistor and burns continuously. If there is a ground anywhere on the system of a lower resistance than the path through the lamp, the lamp will go out, indicating that there is a short in the system.

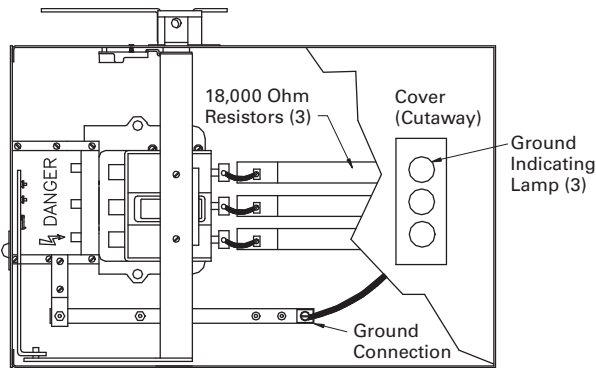

Combination Starter Bus Plugs

Eaton's Freedom™ and Advantage™ motor starters are included in the Pow-R-Way III bus plug product offering. Freedom motor starters offer state-of-the-art features that ensure greater value, flexibility and performance in the toughest commercial and industrial applications.

Advantage motor starters have features including a solid-state, heaterless overload relay with built-in ground fault protection. Advantage also features communication capabilities and an on-board micro-

processor that controls the contactor magnet to eliminate burnout in low voltage or varying control circuit conditions.

Plug-in combination starters or contactors are mounted in enclosures identical to the circuit breaker and fusible switch type bus plugs including the clamp and guides, safety interlocks and guide pin. They are available from size 0 through 5 with a circuit breaker, motor circuit protector or fusible disconnect. Contact Eaton for specific application and outline dimensions.

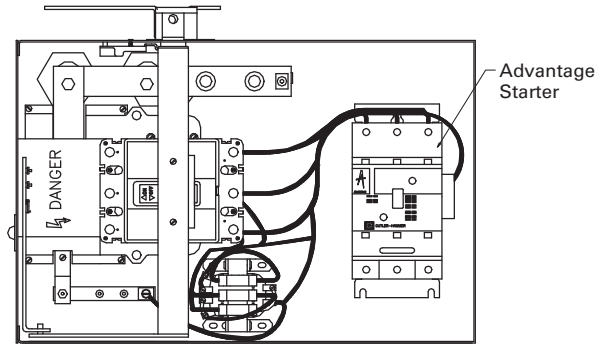

Pow-R-Way III Express Bus

Eaton continues to be a leader in providing service and product solutions to its customers. When you need a complete run of busway fast to get critical electrical loads running or meet time-sensitive deadlines, Express Bus is the solution.

Product Offering

- Indoor plug-in busway:
 - 800–2500A copper and 800–2000A aluminum
- Indoor feeder busway:
 - 800–2500A copper and 800–2000A aluminum
- Corner joints:
 - Forward (right)
 - Rearward (left)
 - Upward
 - Downward
- Tap boxes:
 - End tap box
 - Plug-in tap box
- Bus plugs:
 - Fusible
 - Circuit breaker
- Accessories:
 - End closer
 - Wall/floor flange
 - Hangers

Program Highlights

Eaton will ship 12 total pieces of busway in 5 working days or 24 total pieces in 10 working days after receipt of released order. Total pieces are inclusive of end tap boxes and corner joints.

For pricing, special requests or needs, please contact your local Eaton sale office.

Plug-in units and additional hangers are stocked and available in the warehouse.

How the Program Works

By using the form provided, it's quick and as easy as 1-2-3.

1. Write in the catalog numbers and quantities of the pieces needed.
2. Write in and extend the pricing. Obtain net multipliers from your local sales office.
3. Fax in the order sheet with a copy of your purchase order.

Once received, your order will be entered in the system and shipped within 5 to 10 working days based upon the number of pieces ordered.

Feeder and plug-in indoor busway with copper conductors are available in 10-foot and 6-foot lengths. They can be used interchangeably without the use of special adapters or special splice plates, provided they are the same current and system rating.

Pow-R-Way III is constructed with a lightweight and rugged, two-piece all-aluminum extruded housing, which is rated as a 50% ground path.

Copper busbars for plug-in applications have full-sized conductor tabs welded to their side edges to form the plug-in contact surfaces. Tabs are the same exact thickness as the conductors and are fully rated up to 800A.

Corner Joint Elbows

When it comes to bends and turns in a bus run, the Pow-R-Way III corner joint is the most compact elbow in the industry. Given the complexity of today's industrial and commercial distribution systems and the need to coordinate layouts with HVAC, plumbing and lighting requirements, space quickly becomes a critical factor.

The Pow-R-Way III corner joint elbow can be installed in areas where traditional 90-degree elbows could never have been accomplished before.

Due to its compact design, the corner joint also allows for layouts that provide optimum utilization of space. Critical section length that would normally be required for a traditional elbow leg length can now be dedicated to maximizing usable plug-in section length.

The corner joint is as reliable as traditional elbows. It is seismic certified and exceeds the requirements of both the UBC and CBC (Zone 4). The corner joint is UL listed for indoor applications.



Corner Joint Elbows

Fittings and Accessories

End cable tap boxes are available for all ratings in the Express Bus program. One horizontal hanger will be included for every 10 feet of busway. Please specify flatwise or edgewise.



Corner Joint Elbows

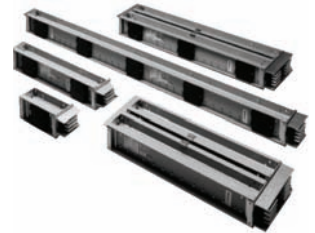

Plug-In and Feeder Busway



Pow-R-Bridge Assembly

Features, Benefits and Functions

Pow-R-Way III Offers a Full Line of Low Voltage Busway to Meet the Needs of the Global Marketplace

Eaton has combined the requirements of NEMA, UL, CSA and IEC into one design to present a world-class product in Pow-R-Way III. With standard features that include a two-piece aluminum housing, finger-safe plug-in outlets, an integral ground path and high 6-cycle short-circuit withstand ratings, Pow-R-Way III provides a busway system that can be used over a broad spectrum of industrial, commercial and institutional applications worldwide.

Product Offering

- **Plug-In Busway**
225–5000A copper and 225–4000A aluminum straight sections of plug-in busway are available in 2 ft (0.6m) incremental lengths from a 2 ft (0.6m) minimum to 10 ft (3m) maximum. Plug-in busway is also available as sprinkler proof
- **Feeder Busway**
225–5000A copper and 225–4000A aluminum straight sections of indoor and outdoor feeder busway available in any length in 1/8-inch (3.2 mm) increments from a 16-inch (406 mm) minimum to a 10-foot (3m) maximum. A wide range of fittings are available in indoor sprinkler-proof, or outdoor feeder busway

• **Plug-In Units**

A full family of busway plug-in units is available. Standard plug-in units include fusible or circuit breaker protection. Advanced plug-in units include Visor Series surge suppression, communicating IQ Energy Sentinel and OPTIM circuit breakers, and Advantage combination contactors and starters. A full line of receptacle plug-in units are available

Product Features and Benefits

- The all-aluminum two-piece housing provides durability and product integrity
- The lightweight and compact design results in easy installation
- The housing combined with a true sandwich design in both plug-in and feeder busway contributes to improve coordination and high short-circuit ratings
- An epoxy insulation process ensures optimum conductor and system protection
- Silver-plated joint and contact surfaces provide high-quality connections
- Highly automated manufacturing processes result in a superior product
- The Pow-R-Bridge joint package and torque indicating bolt gives a rugged, yet flexible and easy-to-install connection
- Corner joint elbows contribute to successful layouts and minimize space limitations

- High 6-cycle short-circuit ratings optimize coordination between busway and power equipment
- This world-class product design and manufacturing meets the requirements of NEMA, CSA, Seismic and ISO® and IEEE®
- Plug-in busway design and an enhanced bus plug-in unit facilitates installation and improves safety
- Flexible ground and neutral options provide solutions for any application problem
- A full family of plug-in units is available for every power need
- Advanced bus plugs provide protection, communication and coordination capabilities

Busway Capabilities

- The busway manufacturing plant in Greenwood, SC, is able to meet your emergency or quick ship requirements with quick ship lead-times from 3 days to 2 weeks
- Customer approval drawings can be available in *2 weeks or less* to meet your project requirements
- Eaton's final field fit program ensures accurate layout and allows for minor last-minute modifications during installation
- Advanced system tools including Bid Manager™ programs provide quick and accurate product information

Standards and Certifications

- Pow-R-Way III meets the requirements of NEMA, UL 857, CSA C22.2 No. 27-94, IEEE, ANSI, IEC 439-1 and 2, IEC 529 and is manufactured in an ISO 9001 certified facility
- Pow-R-Way III meets the International Building Code standards and is certified in the Uniform Building Code® and the California Building Code to exceed Zone 4 requirements
- ANSI, NEMA, IEEE, CSA, UL 857
- 10 kAIC rms symmetrical
- Fused duplex—40A maximum
- Single—70A maximum
- Quad—125A maximum

**Product Support**

Busway product and application support is available from a professional team of Eaton employees that includes field sales engineers, application engineers, engineering service systems and the greenwood busway product engineering services.

Additional Programs

Final Field Fit—This program was established to effectively manage the dimensional uncertainties that are often inherent in bus duct layouts. This program provides the assurance of an exact fit the first time. It allows for bus duct runs to be released for manufacture when certain dimensions are not yet determined. It also eliminates the costly delays that can occur when sections have to be remade in order to accommodate last-minute job site changes in routing. For program details, please see publication SA01702001E.

Field Measurements—

For larger and more complex projects, Eaton will provide factory assistance with taking busway layout measurements. We will take full accountability of all measurements and will ensure an exact fit. Contact your local Eaton sales office for pricing and availability.

Additional Information

- Product Brochure: BR01701001E
- Technical Data: TD01701001E
- Consulting Application Guide: CA08104001E
- Electrical Solutions Catalog: CA08105001E
- ABCs of Planning/Installation: IM01701002E
- Services and Solutions: BR01701002E

Pow-R-Way III

- Technical Data: TD01701001E
- ABCs of Busway: IM01701002E
- Brochure: BR01701001E

Service and Solutions

- Installation and Maintenance: IB01701001E
- Selling Policy: 25-000
- Discount Symbol: CE3-LV Busway
CE4-LV Busway Devices

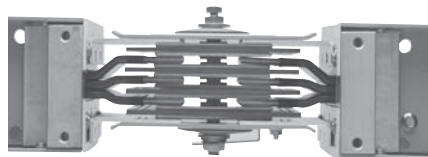
**Bridge Joint Assembly**

6.1 Low Voltage Busway

Pow-R-Way III

Catalog Number Selection

Breaker Unit

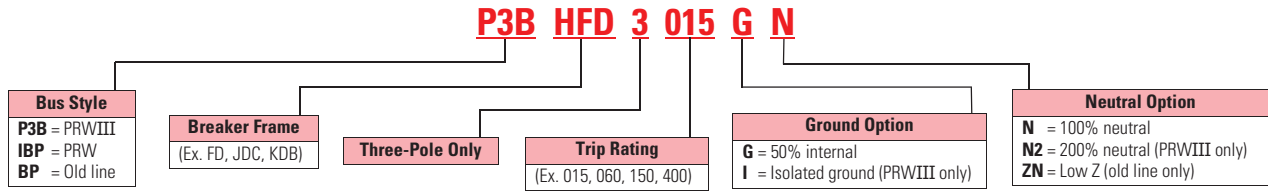

6

Fusible Unit

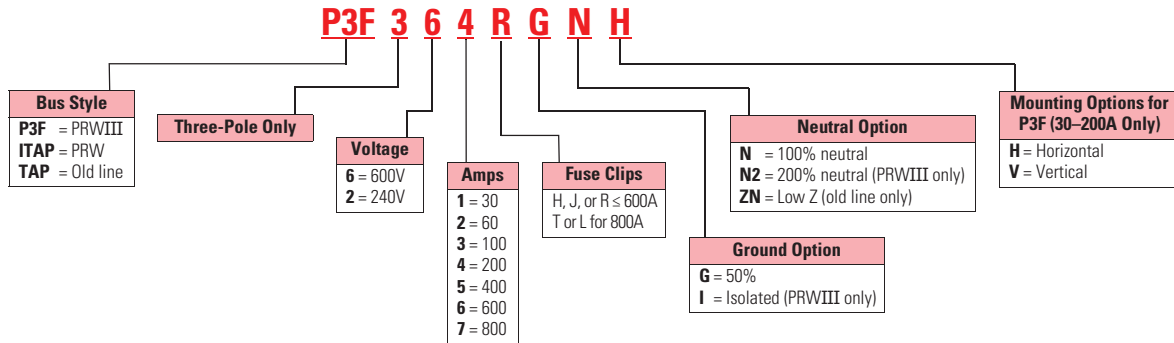

SPD Series Bus Plug

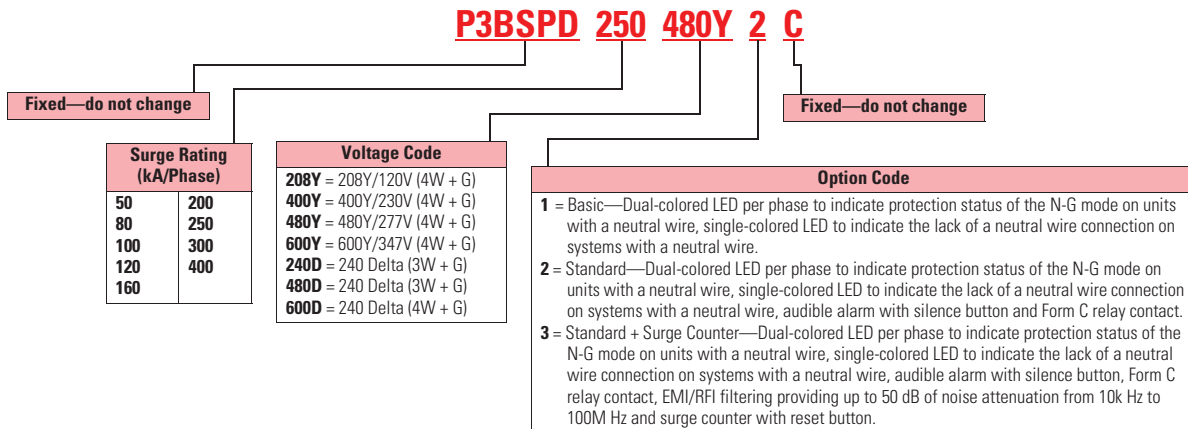

NEMA Receptacle Configuration

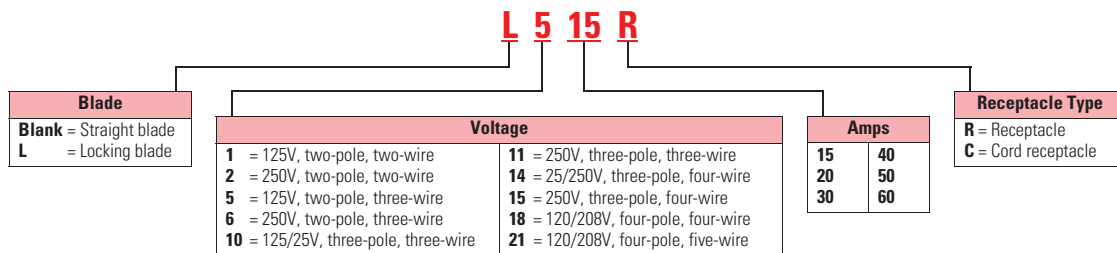

Notes

"H" clips are standard for PRW and old line unless specified by adding "R" in catalog number.

Please call Greenwood low voltage busway department for help in assigning a catalog number for a specific application.

Do not leave spaces between characters. Example: P3BFD3100N; ITAP361N.

All plug-in units come fully assembled.

Product Selection

Circuit Breaker Plug-In Units

Horizontal Install
(Front View)



Horizontal Install
(Rear View)



Circuit Breaker Plug-In Units

Breaker Frame	Ampere Rating	Plug-In Enclosure Catalog Number ①	100% Neutral Stab Catalog Number	50% Internal Ground Stab Catalog Number	50% Isolated Ground Stab Catalog Number	200% Neutral Stab Catalog Number
ED, EDH, EHD, EDC, FDB, FD, HFD, FDC	10–225	P3BFD	P3FDN100	P3FG100	P3FDI100	P3FD2N100
			P3FDN225	—	P3FDI225	P3FD2N225
JDB, JD, HJD, JDC	70–250	P3BJD	P3JDN150	—	P3JDI150	P3JD2N150
			P3JDN250	P3JDG250	P3JDI250	P3JD2N250
KDB, KD, DK, HKD, KDC	100–400	P3BKD	P3KDN400	P3KDG400	P3KDI400	P3KD2N400
LDB, LD, HLD, LDC	300–600	P3BLD	P3MDN800	P3MDG800	P3MDI800	—
MDL, HMDL	400–800	P3BMD	P3MDN800	P3MDG800	P3MDI800	—
ND, HND, NDC	400–800	P3BND	P3NDN800	P3NDG800	P3NDI800	—
FB TRI-PAC	15–100	P3FBFP	P3FBPN100	P3FBPG100	P3FBPI100	—
LA TRI-PAC	75–400	P3BLAP	P3LAPN400	P3LAPG400	P3LAPI400	—
NB TRI-PAC	500–800	P3BNBP	P3NBPN800	P3NBPG800	P3NBPI800	—

- Refer to **Page V2-T6-25** for breaker data; for reference only
- The enclosure, circuit breaker, neutral and ground are ordered and shipped assembled
- Housing ground connection supplied as standard at no additional charge

Circuit Breaker Plug



Advanced Circuit Breaker Plug-Ins

Digitrip OPTIM	Ampere Rating	Plug-In Enclosure Catalog Number	100% Neutral Catalog Number	50% Internal Ground Catalog Number	50% Isolated Ground Catalog Number
L-Frame	70–600	P3BORPL	P3BORPLN600	P3BORPLG600	P3BORPLI600

- The P3BFD, P3BJD and P3BKD plug-in units can be modified to accept breaker mounted IQ Energy Sentinels
- The IQ Energy Sentinel and the OPTIM breaker plug-in units permit multiple meters, remote monitoring, and interconnection with programmable logic controllers and building-management systems. Applications may range from revenue metering for tenant billing to a full-power management system. Consult with an Eaton application engineer or the busway product line for assistance

Notes

① Enclosure not sold separately. Refer to **Page V2-T6-14** for assembled bus plug catalog number. See **Page V2-T6-14** for plug assembled style number configuration.

6.1

Low Voltage Busway

Pow-R-Way III

Fusible Plug-In Units

Pow-R-Way III Plug-In Opening



Fusible Plug-In Units

Ampere Rating	Three-Wire Plug 600V Catalog Number ①	Three-Wire Plug 240V Catalog Number ①	100% Neutral Stab Catalog Number	50% Internal Ground Stab Catalog Number	50% Isolated Ground Stab Catalog Number	200% Neutral Stab Catalog Number
30 (Horizontal)	P3F361RGH	P3F321RGH	②	②	②	②
30 (Vertical)	P3F361RGV	P3F321RGV	②	②	②	②
60 (Horizontal)	P3F362RGH	P3F322RGH	②	②	②	②
60 (Vertical)	P3F362RGV	P3F322RGV	②	②	②	②
100 (Horizontal)	P3F363RGH	P3F323RGH	②	②	②	②
100 (Vertical)	P3F363RGV	P3F323RGV	②	②	②	②
200 (Horizontal)	P3F364RGH	P3F324RGH	②	②	②	②
200 (Vertical)	P3F364RGV	P3F324RGV	②	②	②	②
400	P3F365R	P3F325R	P3FN400	P3FG400	P3FI400	—
600	P3F366R	P3F326R	P3FN600	P3FG800	P3FI800	—
800	P3F367T	P3F327T	P3FN800	P3FG800	P3FI800	—

- Fuses are not included
- Mechanical lugs are provided. If compression lugs are required, the cable size must be specified
- Plug-in unit, neutral and ground are ordered and shipped assembled

Note: See **Page V2-T6-14** for plug assembled style number configuration.

- Housing ground connection supplied as standard at no additional charge
- R-Fuse clips are supplied as standard

- If J-Fuse clips are required, replace "R" in the catalog number with a "J" (30–600A, 600V only)
- 800A, 600V also available with L-Fuse clips; replace "T" in the catalog number with "L"

Pow-R-Way III Plug (Rear View)



Special Industry Fusible Plug-In Units

Ampere Rating	Enclosure 600V Catalog Number	100% Neutral Stab Catalog Number	50% Internal Ground Stab Catalog Number	50% Isolated Ground Stab Catalog Number	Terminal Kit Compression Lugs		
					Number Per Phase	Wire Size	Catalog Number
30	P3F361H	③	③	③	1	1-#12 to #10	CTK30SC
60	P3F362H	③	③	③	1	1-#8	CTK60SC
100	P3F363H	③	③	③	1	1-#4	CTK100SC
200	P3F364H	③	③	③	1	1-2/0	CTK200BSC
400	P3F365H	③	③	③	1	1-750 kcmil	CTK400SPW
600	P3F366H	③	③	③	2	2-500 kcmil	CTK600DPM

- Fuses are not included
- Housing ground connection supplied as standard at no additional charge

- Grounding compression lug included on 200A and above. Lugs are ordered and shipped separately; fuses are not included

- H-Fuse clips are supplied as standard
- If J- or R-Fuse clips are required, order by description

Notes

- ① "H" and "V" do not denote mounting orientation of the bus plug. Horizontal (H) and Vertical (V) refer to the orientation of the bus system that the plug will be installed on.
- ② Neutral and ground kits are not capable of being field installed in these units. Order bus plugs with fully assembled part numbers. See Catalog Number Selection on **Page V2-T6-14** for details.
- ③ Grounds and neutrals must be factory assembled. Order by description. See **Page V2-T6-25**.

Special Plug-In Units

Plug-In Cable Tap Box Units

Ampere Rating	Plug-in Cable Tap Box 600V Enclosure Catalog Number	100% Neutral Stab Catalog Number	50% Internal Ground Stab Catalog Number	50% Isolated Ground Stab Catalog Number
200	P3PTB200	P3PTBN200	P3PTBG200	P3PTBI200
400	P3PTB400	P3PTBN400	P3PTBG400	P3PTBI400
600	P3PTB600	P3PTBN600	P3PTBG600	P3PTBI600
800	P3PTB800	P3PTBN800	P3PTBG800	P3PTBI800

- Mechanical lugs are provided. If compression lugs are required, the cable size must be specified

Plug-In Combination Starters and Contactors (Non-Reversing, Three-Pole)

NEMA Size	Freedom Starter		Freedom Contact		Advantage Starter		Advantage Contact	
	Fusible	Circuit Breaker	Fusible	Circuit Breaker	Fusible	Circuit Breaker	Fusible	Circuit Breaker
0	P3FSTR0F	P3BSTR0F	P3FC0N0F	P3BC0N0F	P3FSTR0A	P3BSTR0A	P3FC0N0A	P3BC0N0A
1	P3FSTR1F	P3BSTR1F	P3FC0N1F	P3BC0N1F	P3FSTR1A	P3BSTR1A	P3FC0N1A	P3BC0N1A
2	P3FSTR2F	P3BSTR2F	P3FC0N2F	P3BC0N2F	P3FSTR2A	P3BSTR2A	P3FC0N2A	P3BC0N2A
3	P3FSTR3F	P3BSTR3F	P3FC0N3F	P3BC0N3F	P3FSTR3A	P3BSTR3A	P3FC0N3A	P3BC0N3A
4	P3FSTR4F	P3BSTR4F	P3FC0N4F	P3BC0N4F	P3FSTR4A	P3BSTR4A	P3FC0N4A	P3BC0N4A

6.1

Low Voltage Busway

Pow-R-Way III

Bolt-On Units

Circuit Breaker Bolt-On Units

Breaker Frame	Ampere Rating	Bolt-On Enclosure Catalog Number	100% Neutral Stab Catalog Number	50% Internal Ground Stab Catalog Number	50% Isolated Ground Stab Catalog Number
EHD, FDB, FD, HFD, FDC	15–225	P3BFDBO	P3FDNBO	P3FDGBO	P3FDIBO
JDB, JD, HJD, JDC	70–250	P3BJDBO	P3FDNBO	P3JDGBO	P3JDIBO
KDB, KD, HKD, KDC	250–400	P3BKDBO	P3KDNBO	P3KDGBO	P3KDIBO
LDB, LD, HLD, LDC	300–600	P3BLDBO	P3LDNBO	P3LDGBO	P3LDIBO
MDL, HMDL	500–800	P3BMDBO	P3MDNBO	P3MDGBO	P3MDIBO
ND, HND	900–1200	P3BNDBO	P3NDNBO	P3NDGBO	P3NDIBO

- Factory assembled, refer to Eaton's busway for delivery
- Refer to **Page V2-T6-25** for breaker data, for reference only
- Bolt-on units **require a Power Take-off** at the rating of the busway
- Housing ground connection supplied as standard

Fusible Bolt-On Units

Ampere Rating	Enclosure 600V Catalog Number	100% Neutral Stab Catalog Number	50% Internal Ground Stab Catalog Number	50% Isolated Ground Stab Catalog Number
30	P3F361BO	P3FN100BO	P3FG100BO	P3FI100BO
60	P3F362BO	P3FN100BO	P3FG100BO	P3FI100BO
100	P3F363BO	P3FN100BO	P3FG100BO	P3FI100BO
200	P3F364BO	P3FN250BO	P3FG250BO	P3FI250BO
400	P3F365BO	P3FN400BO	P3FG400BO	P3FI400BO
600	P3F366BO	P3FN600BO	P3FG600BO	P3FI600BO
800	P3F367BO	P3FN800BO	P3FG800BO	P3FI800BO
1200	P3F369BO	P3FN1200BO	P3FG1200BO	P3FI1200BO

- Factory assembled; refer to Eaton's busway for delivery
- Bolt-on units **require a power take-off** at the rating of the busway
- If neutral and ground are required, order by description with bolt-on unit
- Housing ground connection supplied as standard

Ground Detector Neutralizer Plug (Three-Wire)

Maximum Voltage	Catalog Number
600	P3GND

Technical Data and Specifications

Ratings

- A. The busway shall be Eaton's type Pow-R-Way III: [three-phase, three-wire] [three-phase, three-wire with 50% housing ground and/or 50% internal ground] [three-phase, three-wire with 50% housing ground and/or 50% isolated ground] [three-phase, four-wire with 100% neutral] [three-phase, four-wire with 100% neutral, 50% housing and/or 50% internal ground] [three-phase, four-wire with 100% neutral, 50% housing and/or 50% isolated ground] [three-phase, four-wire with 200% neutral] [three-phase, four-wire with 200% neutral, 50% housing ground, and/or 50% internal ground] [three-phase, four-wire with 200% neutral, 50% housing ground, and/or 50% isolated ground] with voltage and current ratings as indicated on the contract drawings.
- B. The busway shall have a minimum of 6-cycle short-circuit rating of 85 kA rms symmetrical for ratings through 800A, 100 kA rms symmetrical for ratings through 1350A, 125 kA rms symmetrical for ratings through 1600A, 150 kA rms symmetrical for ratings through 2500A, and 200 kA rms symmetrical for ratings through 5000A.

Construction

- A. The busway and associated fittings shall consist of [aluminum] [copper] conductors totally enclosed in a two-piece extruded aluminum housing. Outdoor feeder, indoor feeder and indoor plug-in busway shall be interchangeable at the same rating without the use of adapters or special splice plates. Fittings—such as elbows, tees, flanges, etc.—shall be identical for use with both the plug-in and feeder types of busway. The busway shall be capable of being mounted flatwise, edgewise or vertically without derating. The busway shall consist of standard 10 ft (3m) sections with special sections and fittings provided to suit the installation. Horizontal runs shall be suitable for hanging on 10 ft (3m) maximum centers. Vertical runs shall be suitable for mounting on 16 ft (4m) maximum centers. Provide one hanger for every 10 ft (3m) of horizontally mounted duct. On vertical runs, provide one adjustable hanger per floor.

Bus

- A. Busbars shall be fabricated from high strength, [57% conductivity aluminum] [99% conductivity copper] and suitably plated at all electrical contact surfaces.

- B. Busbars shall be insulated over their entire length, except at joints and contact surfaces, with a UL-listed insulating material consisting of epoxy applied by fluidized bed process. Tape or heat-shrink sleeve insulation, or any other method of insulation that can allow air gaps or insulation breakdown, shall not be acceptable.
- C. The busway shall be capable of carrying rated current continuously without exceeding a temperature rise of 55°C based on a 40°C ambient.

Bus Joints

- A. Each busway section shall be furnished complete with joint hardware and covers. The busway joints shall be a single-bolt, non-rotating, removable bridge design. All bridge joints shall be furnished with torque-indicating double-head joint bolts and Belleville washers. The bridge joint shall utilize a captive nut retainer on the opposite side of the torque indicating bolt. The bridge joint design shall ensure proper installation without the use of a torque wrench, and provide visual indication that the joint is properly torqued. Each busway joint shall allow for a minimum length adjustment of ± 0.5 inches (12.7 mm). De-energization of busway shall not be required for safe testing of joint tightness.

Housing

- A. The busway housing shall be a two-piece design fabricated from extruded aluminum. The two-piece housing shall be bolted together along the bottom flange. The busway enclosure finish shall be ANSI 61 gray baked epoxy powder paint applied by an electrostatic process.
- B. Outdoor feeder busway housing shall be identical to indoor feeder busway housings, and shall be UL listed for outdoor use.

Plug-In Busway

- A. Where required, busway shall be of the plug-in type. Plug-in busway shall be available in standard 2-, 4-, 6-, 8- and 10-foot lengths, with plug-in openings provided on both sides of the busway sections on 2 ft (0.6m) centers. Plug-in covers shall prevent dirt and debris from entering contact plug-in openings in the busway. The design shall allow for 10 hinged cover outlets per 10 ft (3m) of plug-in length. Covers for plug-in openings shall have a positive screw close feature and provisions for the installation of power company seals. The contact surfaces for bus plug stabs shall be silver-plated of the same material, thickness and rating as the stab bars. The stabs shall be welded to the busbars. A standard housing ground connection shall be supplied in each plug-in opening. Positive mechanical guides for plug-in units shall be provided at each plug-in opening to facilitate unit alignment and prevent improper installation.

6.1

Low Voltage Busway

Pow-R-Way III

6

B. Where required, plug-in units of the types and ratings indicated on the plans and specifications shall be supplied. Plug-in units shall be mechanically interlocked with the busway housing to prevent their installation or removal when the switch is in the ON position. The enclosure of any plug-in unit shall make positive ground connection to the duct housing before the stabs make contact with the busbars. All plug-in units shall be equipped with a defeatable interlock to prevent the cover from being opened while the switch is in the ON position and prevent accidental closing of the switch while the cover is open. The plugs shall be provided with a means for padlocking the cover closed and padlocking the disconnect device in the OFF position. The operating handle and mechanism shall remain in control of the disconnect device at all times, permitting its easy operation from the floor by means of a hookstick or chain. For safety reasons, no projections shall extend into the busway housing other than the plug-in stabs. All plug-in units shall be interchangeable without alteration or moderation of plug-in duct.

C. Fusible-type plugs shall have a quick-make/quick-break disconnect switch and positive pressure fuse clips.

—OR—

C. Circuit-breaker-type plugs shall have an interrupting rating of not less than symmetrical rms amperes or be series rated as otherwise shown in the contract document and shall meet all requirements of UL Standard 489. It shall be possible to increase the interrupting rating of a breaker plug-in device having ampere ratings through 400A up to 100 kAIC at 480 Vac and 200 kAIC at 240 Vac by changing out the circuit breaker only and leaving the enclosure intact. All breaker plug-in devices shall be Eaton type Series C.

Surge Protective Device

A. Provide surge protective device as specified in Section 16671.

Short-Circuit Withstand Ratings—rms Symmetrical Amperes for Copper Pow-R-Way III Plug-In and Feeder Busway

Ampere Rating	6-Cycle Copper
225	85,000
400	85,000
600	85,000
800	85,000
1000	100,000
1200	100,000
1350	100,000
1600	125,000
2000	150,000
2500	150,000
3200	200,000
4000	200,000
5000	200,000

Short-Circuit Withstand Ratings—rms Symmetrical Amperes for Aluminum Pow-R-Way III Plug-In and Feeder Busway

Ampere Rating	6-Cycle Aluminum
225	85,000
400	85,000
600	85,000
800	100,000
1000	100,000
1200	125,000
1350	150,000
1600	150,000
2000	150,000
2500	200,000
3200	200,000
4000	200,000
5000	—

Pow-R-Way III Plug-In Busway

- 225–5000A copper
- 225–4000A aluminum

Straight sections of plug-in busway are made only in 24-inch (609.6 mm) incremental lengths with a maximum length of 10 ft (3m). **Page V2-T6-28** depicts the configuration of plug-in busway and Pow-R-Bridge for the available ampere ratings. See table below for reference to the proper configuration. Available in indoor and sprinkler-proof ratings.

Configuration

Ampere Rating			
UL 857		IEC 439	Configuration (see Page V2-T6-28)
Cu	Al	Cu	
225	225	225	A
400	400	400	A
600	630	630	A
800	800	1000	A
1000	1000	1200	A
1200	1200	1400	A
1350	1350	1550	A
1600	—	1800	A
2000	—	2250	A
—	1600	—	B
2500	2000	3000	B
3200	—	3800	C
4000	2500	4500	C
—	3200	—	D
5000	4000	5800	D

IEC 60529 IP Ratings

IEC 529 IP Rating	Busway Type
IP2X	Pow-R-Way III plug-in busway; plug-in outlet protects against access to live parts
IP40	Pow-R-Way III indoor plug-in and feeder busway
IP55	Pow-R-Way III sprinkler-proof plug-in busway
IP66	Pow-R-Way III outdoor feeder busway

IEC 60529 Degrees of Protection

IEC 529 IP Rating	Description
IP40	Protection against access to hazardous parts with a wire or solid foreign object 1 mm diameter. No protection against water.
IP55	Protection against access to hazardous parts with a wire and dust shall not penetrate in quantity to interfere with satisfactory operation or impair safety. Protects against water jets.
IP66	Protection against access to hazardous parts with a wire and dust shall not penetrate in quantity to interfere with satisfactory operation or impair safety. Protects against powerful water jets.

Pow-R-Way III Feeder Busway

- 225–5000A copper
- 225–4000A aluminum

Straight sections of feeder busway can be supplied in any length, at 1/8-inch (3.2 mm) increments, from a 16-inch (406.4 mm) minimum to a 10 ft (3m) maximum.

Page V2-T6-28 illustrates the configuration of feeder busway and Pow-R-Bridge for the available ampere ratings. See table below for reference to the proper configuration.

Feeder Busway Configuration

Ampere Rating			
UL 857		IEC 439	Configuration (see Page V2-T6-28)
Cu	Al	Cu	
225	225	225	A
400	400	400	A
600	600	630	A
800	800	1000	A
1000	1000	1200	A
1200	1200	1400	A
1350	1350	1550	A
1600	—	1800	A
2000	—	2250	A
—	1600	—	B
2500	2000	3000	B
3200	—	3800	C
4000	2500	4500	C
—	3200	—	D
5000	4000	5800	D

Each section will include one factory-installed Pow-R-Bridge mounted to the left end of the busway (with the “T” to the top, when viewing the bus from the “F” side). Each Pow-R-Bridge will have a “T” label, which must always match the “T” orientation of the busway. Available in indoor, sprinkler-proof and outdoor ratings. See IEC 60529 IP Ratings table to the left for details.

6.1

Low Voltage Busway

Pow-R-Way III

6

Circuit Breaker Plug-In Units

Circuit Breakers

100% rated breakers are not available for use in bus plugs. Contact product line for guidance.

Ampere Rating	Interrupting Rating (kA Symmetrical)			Breaker Type
	240 Vac	480 Vac	600 Vac	
15-60	18	14	—	EHD
70-100	18	14	—	EHD
15-60	18	14	14	FDB
70-100	18	14	14	FDB
110-150	18	14	14	FDB
15-60	65	35	18	FD
70-100	65	35	18	FD
110-150	65	35	18	FD
175-225	65	35	18	FD
15-60	100	65	25	HFD
70-100	100	65	25	HFD
110-150	100	65	25	HFD
175-225	100	65	25	HFD
15-60	200	100	35	FDC
70-100	200	100	35	FDC
110-225	200	100	35	FDC
15-100	200	150	—	FCL
100-225	65	—	—	ED
100-225	100	—	—	EDH
100-225	200	—	—	EDC
70-225	65	35	18	JD, JDB
250	65	35	18	JD, JDB
70-225	100	65	25	HJD
250	100	65	25	HJD
70-225	200	100	35	JDC
250	200	100	35	JDC
125-250	200	200	100	LCL
250-400	65	—	—	DK
100-400	65	35	25	KD, KDB
100-400	100	65	35	HKD
100-400	200	100	65	KDC
200-400	200	200	—	LCL
300-600	65	35	25	LD, LDB
300-600	100	65	35	HLD
300-600	200	100	50	LDC
400-800	65	50	25	MDL
400-800	100	65	35	HMDL
400-800	65	50	25	ND
400-800	100	65	35	HND
400-800	200	100	50	NDC
600-1200	65	50	25	ND
600-1200	100	65	35	HND
600-1200	200	100	50	NDC

Branch Devices Earth Leakage Ground Fault Circuit Breakers

(Adjustable pickup from 30 mA to 30A)

Ampere Rating	kAIC (Symmetrical)		Breaker Type
	480 Vac	600 Vac	
35-60	25	—	ELFD
70-100	25	—	ELFD
110-150	25	—	ELFD
35-60	65	—	ELHFD
70-100	65	—	ELHFD
110-150	65	—	ELHFD
35-60	100	—	ELFDC
70-100	100	—	ELFDC
110-150	100	—	ELFDC
100-250	35	—	ELJD
100-250	65	—	ELHJD
100-250	100	—	ELJDC
200-400	35	—	ELKD
200-400	65	—	ELHKD
200-400	100	—	ELKDC

Integrally Fused, Current-Limiting Circuit Breaker

Ampere Rating	Interrupting Rating (kA Symmetrical)			Breaker Type
	240 Vac	480 Vac	600 Vac	
15-100	200	200	200	FB-P
125-225	200	200	200	LA-P
250-400	200	200	200	LA-P
400-600	200	200	200	NB-P
700-800	200	200	200	NB-P

Fusible Switch Horsepower Ratings

Ampere Rating	240V		480V		600V	
	NEC Std.	Max.	NEC Std.	Max.	NEC Std.	Max.
30	3	7.5	5	15	7.5	20
60	7.5	15	15	30	15	50
100	15	30	25	60	30	75
200	25	60	50	125	60	150
400	50	125	100	250	125	350
600	75	200	150	400	200	500
800	100	250	200	500	250	500

Dimensions

Approximate Dimensions in Inches (mm)

Busbar and Housing

Three-Wire with No Neutral

Ampere Rating	Phase Bar Size		Bar Per Phase	Wire Designation and Housing Size			Figure ①				
	Cu	Al		50% Integral Housing Ground 3WH	50% Internal Ground Bus 3WHG	50% Internal Isolated Ground 3WI					
	Depth	Width	Width	Height	Width	Height					
225	225	0.25 (6.4)	1.62 (41.1)	1	4.75 (120.7)	4.38 (111.3)	4.75 (120.7)	4.50 (114.3)	4.75 (120.7)	4.55 (115.6)	A
400	400	0.25 (6.4)	1.62 (41.1)	1	4.75 (120.7)	4.38 (111.3)	4.75 (120.7)	4.50 (114.3)	4.75 (120.7)	4.55 (115.6)	A
600	—	0.25 (6.4)	1.62 (41.1)	1	4.75 (120.7)	4.38 (111.3)	4.75 (120.7)	4.50 (114.3)	4.75 (120.7)	4.55 (115.6)	A
800	600	0.25 (6.4)	1.62 (41.1)	1	4.75 (120.7)	4.38 (111.3)	4.75 (120.7)	4.50 (114.3)	4.75 (120.7)	4.55 (115.6)	A
1000	—	0.25 (6.4)	2.25 (57.2)	1	5.38 (136.7)	4.38 (111.3)	5.38 (136.7)	4.50 (114.3)	5.38 (136.7)	4.55 (115.6)	A
1200	800	0.25 (6.4)	2.75 (70.0)	1	5.88 (149.4)	4.38 (111.3)	5.88 (149.4)	4.50 (114.3)	5.88 (149.4)	4.55 (115.6)	A
1350	1000	0.25 (6.4)	3.25 (82.3)	1	6.38 (162.10)	4.38 (111.3)	6.38 (162.1)	4.50 (114.3)	6.38 (162.10)	4.55 (115.6)	A
1600	1200	0.25 (6.4)	4.25 (108.0)	1	7.38 (187.5)	4.38 (111.3)	7.38 (187.5)	4.50 (114.3)	7.38 (187.5)	4.55 (115.6)	A
2000	1350	0.25 (6.4)	5.50 (139.7)	1	8.64 (219.5)	4.38 (111.3)	8.64 (219.5)	4.50 (114.3)	8.64 (219.5)	4.55 (115.6)	A
—	1600	0.25 (6.4)	6.25 (158.8)	1	9.40 (238.8)	4.38 (111.3)	9.40 (238.8)	4.50 (114.3)	9.40 (238.8)	4.55 (115.6)	A
2500	2000	0.25 (6.4)	8.00 (203.2)	1	11.17 (283.7)	4.38 (111.3)	11.17 (283.7)	4.50 (114.3)	11.17 (283.7)	4.55 (115.6)	A
3200	—	0.25 (6.4)	4.25 (108.0)	2	16.14 (410.0)	4.38 (111.3)	16.14 (410.0)	4.50 (114.3)	16.14 (410.0)	4.55 (115.6)	B
4000	2500	0.25 (6.4)	5.50 (139.7)	2	18.64 (473.5)	4.38 (111.3)	18.64 (473.5)	4.50 (114.3)	18.64 (473.5)	4.55 (115.6)	B
—	3200	0.25 (6.4)	6.25 (158.8)	2	20.16 (512.0)	4.38 (111.3)	20.16 (512.0)	4.50 (114.3)	20.16 (512.0)	4.55 (115.6)	B
5000	4000	0.25 (6.4)	8.00 (203.2)	2	23.70 (602.0)	4.38 (111.3)	23.70 (602.0)	4.50 (114.3)	23.70 (602.0)	4.55 (115.6)	B

Four-Wire with 100% Neutral

Ampere Rating	Phase and Neutral Bar Size		Bar Per Phase	Wire Designation and Housing Size			Figure ①				
	Cu	Al		50% Integral Housing Ground 4WH	50% Internal Ground 4WHG	50% Internal Isolated Ground 4WI					
	Depth	Width	Width	Height	Width	Height					
225	225	0.25 (6.4)	1.62 (41.1)	1	4.75 (120.7)	4.38 (111.3)	4.75 (120.7)	4.50 (114.3)	4.75 (120.7)	4.55 (115.6)	A
400	400	0.25 (6.4)	1.62 (41.1)	1	4.75 (120.7)	4.38 (111.3)	4.75 (120.7)	4.50 (114.3)	4.75 (120.7)	4.55 (115.6)	A
600	—	0.25 (6.4)	1.62 (41.1)	1	4.75 (120.7)	4.38 (111.3)	4.75 (120.7)	4.50 (114.3)	4.75 (120.7)	4.55 (115.6)	A
800	600	0.25 (6.4)	1.62 (41.1)	1	4.75 (120.7)	4.38 (111.3)	4.75 (120.7)	4.50 (114.3)	4.75 (120.7)	4.55 (115.6)	A
1000	—	0.25 (6.4)	2.25 (57.2)	1	5.38 (136.7)	4.38 (111.3)	5.38 (136.7)	4.50 (114.3)	5.38 (136.7)	4.55 (115.6)	A
1200	800	0.25 (6.4)	2.75 (70.0)	1	5.88 (149.4)	4.38 (111.3)	5.88 (149.4)	4.50 (114.3)	5.88 (149.4)	4.55 (115.6)	A
1350	1000	0.25 (6.4)	3.25 (82.3)	1	6.38 (162.1)	4.38 (111.3)	6.38 (162.1)	4.50 (114.3)	6.38 (162.1)	4.55 (115.6)	A
1600	1200	0.25 (6.4)	4.25 (108.0)	1	7.38 (187.5)	4.38 (111.3)	7.38 (187.5)	4.50 (114.3)	7.38 (187.5)	4.55 (115.6)	A
2000	1350	0.25 (6.4)	5.50 (139.7)	1	8.64 (219.5)	4.38 (111.3)	8.64 (219.5)	4.50 (114.3)	8.64 (219.5)	4.55 (115.6)	A
—	1600	0.25 (6.4)	6.25 (158.8)	1	9.40 (238.8)	4.38 (111.3)	9.40 (238.8)	4.50 (114.3)	9.40 (238.8)	4.55 (115.6)	A
2500	2000	0.25 (6.4)	8.00 (203.2)	1	11.17 (283.7)	4.38 (111.3)	11.17 (283.7)	4.50 (114.3)	11.17 (283.7)	4.55 (115.6)	A
3200	—	0.25 (6.4)	4.25 (108.0)	2	16.14 (410.0)	4.38 (111.3)	16.14 (410.0)	4.50 (114.3)	16.14 (410.0)	4.55 (115.6)	B
4000	2500	0.25 (6.4)	5.50 (139.7)	2	18.64 (473.5)	4.38 (111.3)	18.64 (473.5)	4.50 (114.3)	18.64 (473.5)	4.55 (115.6)	B
—	3200	0.25 (6.4)	6.25 (158.8)	2	20.16 (512.0)	4.38 (111.3)	20.16 (512.0)	4.50 (114.3)	20.16 (512.0)	4.55 (115.6)	B
5000	4000	0.25 (6.4)	8.00 (203.2)	2	23.70 (602.0)	4.38 (111.3)	23.70 (602.0)	4.50 (114.3)	23.70 (602.0)	4.55 (115.6)	B

Note

① Refer to drawing on **Page V2-T6-27**.

6.1

Low Voltage Busway

Pow-R-Way III

Approximate Dimensions in Inches (mm)

Four-Wire with 200% Neutral

Ampere Rating		Phase Bar Size Neutral Bar is 0.5 (12.7) x Width Shown		Bar Per Phase	Wire Designation and Housing Size						Figure
Cu	Al	Depth	Width		50% Integral Housing Ground 4WNH	50% Internal Ground Bus 4WNG	50% Internal Isolated Ground 4WNI	Width	Height	Width	
225	225	0.25 (6.4)	1.62 (41.1)	1	4.75 (120.7)	4.92 (125.0)	4.75 (120.7)	5.05 (128.3)	4.75 (120.7)	5.10 (129.5)	A
400	400	0.25 (6.4)	1.62 (41.1)	1	4.75 (120.7)	4.92 (125.0)	4.75 (120.7)	5.05 (128.3)	4.75 (120.7)	5.10 (129.5)	A
600	—	0.25 (6.4)	1.62 (41.1)	1	4.75 (120.7)	4.92 (125.0)	4.75 (120.7)	5.05 (128.3)	4.75 (120.7)	5.10 (129.5)	A
800	600	0.25 (6.4)	1.62 (41.1)	1	4.75 (120.7)	4.92 (125.0)	4.75 (120.7)	5.05 (128.3)	4.75 (120.7)	5.10 (129.5)	A
1000	—	0.25 (6.4)	20.25 (512.7)	1	5.38 (136.7)	4.92 (125.0)	5.38 (136.7)	5.05 (128.3)	5.38 (136.7)	5.10 (129.5)	A
1200	800	0.25 (6.4)	2.75 (70.0)	1	5.88 (149.4)	4.92 (125.0)	5.88 (149.4)	5.05 (128.3)	5.88 (149.4)	5.10 (129.5)	A
1350	1000	0.25 (6.4)	30.25 (773.3)	1	6.38 (162.1)	4.92 (125.0)	6.38 (162.1)	5.05 (128.3)	6.38 (162.1)	5.10 (129.5)	A
1600	1200	0.25 (6.4)	40.25 (1023.0)	1	7.38 (187.5)	4.92 (125.0)	7.38 (187.5)	5.05 (128.3)	7.38 (187.5)	5.10 (129.5)	A
2000	1350	0.25 (6.4)	5.50 (139.7)	1	8.64 (219.5)	4.92 (125.0)	8.64 (219.5)	5.05 (128.3)	8.64 (219.5)	5.10 (129.5)	A
—	1600	0.25 (6.4)	60.25 (1533.8)	1	9.40 (238.8)	4.92 (125.0)	9.40 (238.8)	5.05 (128.3)	9.40 (238.8)	5.10 (129.5)	A
2500	2000	0.25 (6.4)	8.00 (203.2)	1	11.17 (283.7)	4.92 (125.0)	11.17 (283.7)	5.05 (128.3)	11.17 (283.7)	5.10 (129.5)	A
3200	—	0.25 (6.4)	40.25 (1023.0)	2	16.14 (410.0)	4.92 (125.0)	16.14 (410.0)	5.05 (128.3)	16.14 (410.0)	5.10 (129.5)	B
4000	2500	0.25 (6.4)	5.50 (139.7)	2	18.64 (473.5)	4.92 (125.0)	18.64 (473.5)	5.05 (128.3)	18.64 (473.5)	5.10 (129.5)	B
—	3200	0.25 (6.4)	60.25 (1533.8)	2	20.16 (512.0)	4.92 (125.0)	20.16 (512.0)	5.05 (128.3)	20.16 (512.0)	5.10 (129.5)	B
5000	4000	0.25 (6.4)	8.00 (203.2)	2	23.70 (602.0)	4.92 (125.0)	23.70 (602.0)	5.05 (128.3)	23.70 (602.0)	5.10 (129.5)	B

Single and Double Module Cross-Sections

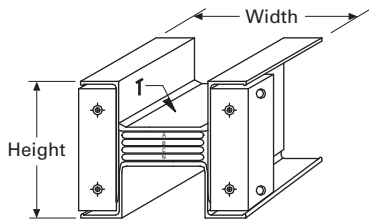

Figure A

225–2000A Aluminum
225–2500A Copper

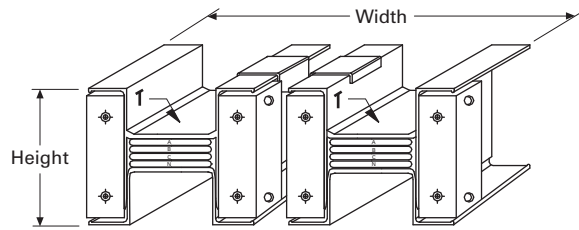
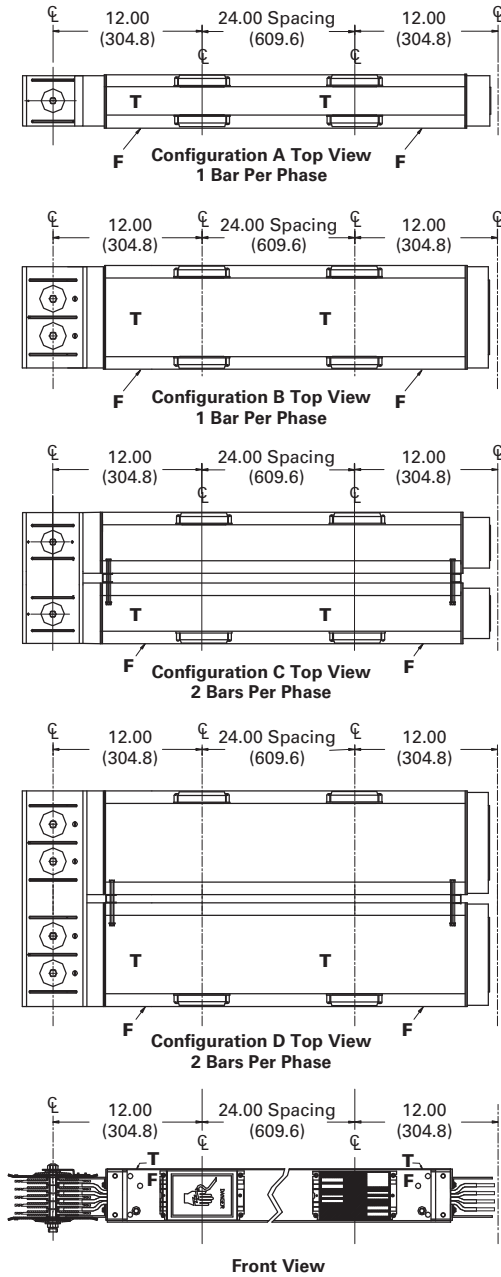

Figure B

2500–4000A Aluminum
3200–5000A Copper

Approximate Dimensions in Inches (mm)

Plug-In Busway



Feeder Busway

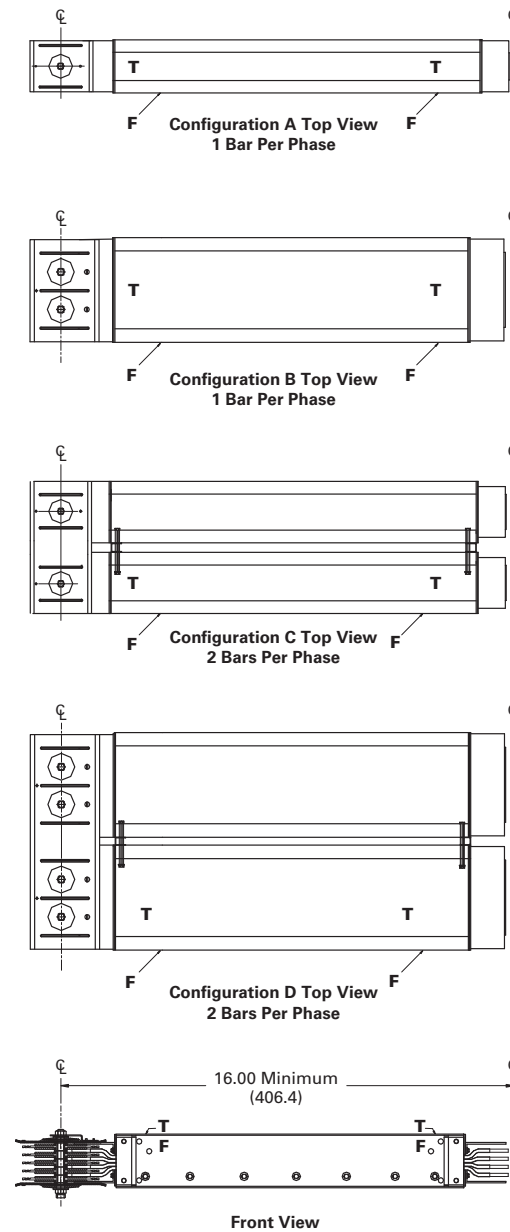

The table below illustrates the quantity of plug-in openings per side that are available per standard section.

Number of Plug-In Openings

Duct Length	Number of Plug-In Openings	
	Front	Back
24.00 (609.6)	1	1
48.00 (1219.2)	2	2
72.00 (1828.8)	3	3
96.00 (2438.4)	4	4
120.00 (3048.0)	5	5

6.1 Low Voltage Busway

Pow-R-Way III

Approximate Dimensions in Inches (mm)

Quad Receptacle Unit

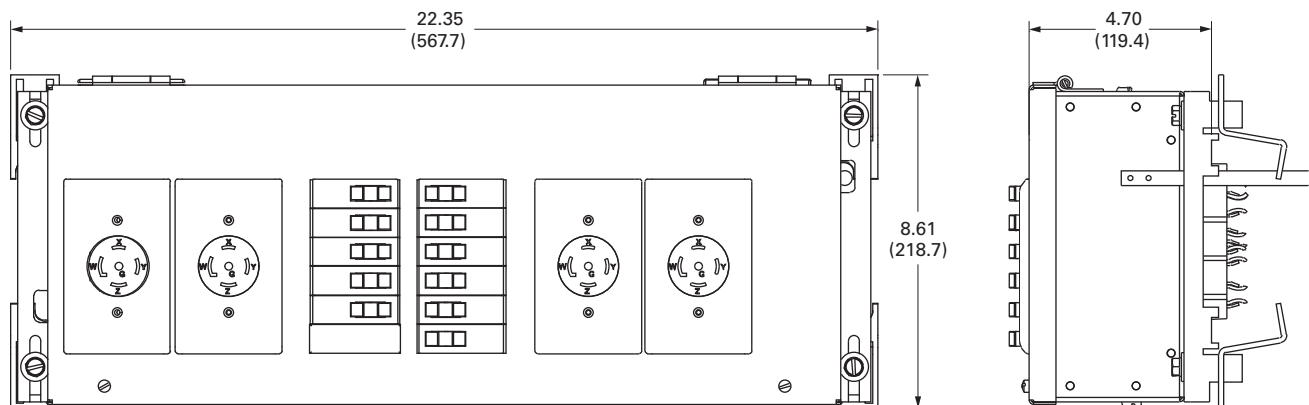

Single Receptacle Unit

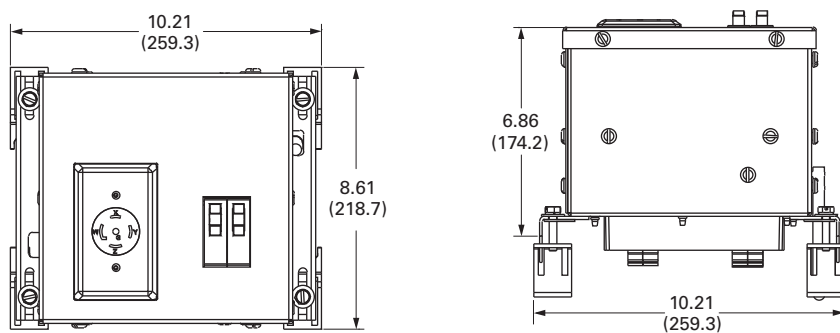

6

Approximate Dimensions in Inches (mm)

Plug-In Units—Physical Data

Bus Plugs

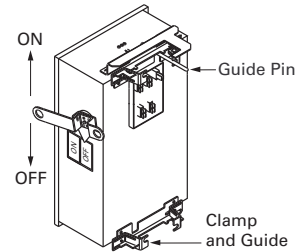
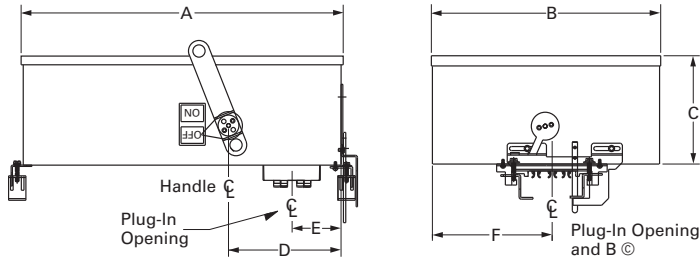

Plug-In Units

Plug-In Unit	Max. Amperes	Max. Vac	Dimensions						Mechanical Terminal Wire Range Per Phase (mm ²)	Approx. Weights Lbs (kg)
			A	B	C	D	E	F		
Circuit Breaker Plug-In Units										
P3BFD (E- & F-Frame)	225	600	21.20 (538.5)	12.36 (314.0)	5.43 (138.0)	4.00 (101.6)	6.25 (158.8)	6.06 (153.7)	100A-(1) #14-1/0 (2.5-50) 150A-(1) #4-4/0 (25-95)	25 (11.3)
P3BJD (J-Frame)	250	600	23.26 (590.8)	12.36 (314.0)	6.97 (177.0)	4.00 (101.6)	10.44 (265.2)	6.06 (153.7)	250A-(1) #14-350 kcmil (25-185) 225A-(1) 3-350 kcmil (35-185)	47 (21.3)
P3BKD (K-Frame)	400	600	34.41 (874.0)	13.29 (337.6)	7.79 (197.9)	4.00 (101.6)	12.56 (319.0)	6.64 (168.7)	350A-(1) 250-500 kcmil (120-240) 400A-(2) 3/0-250 kcmil (45-120)	53 (24.0)
P3BLD (L-Frame)	600	600	41.91 (1064.5)	19.65 (499.1)	10.15 (257.8)	4.00 (101.6)	17.38 (441.5)	9.83 (249.7)	400A-(1) 4/0-600 kcmil (120-300) 600A-(2) 400-500 kcmil (185-240)	75 (34.0)
P3BMDL (MDL-Frame)	800	600	45.89 (1165.6)	19.65 (499.1)	10.15 (257.8)	4.00 (101.6)	17.38 (441.5)	9.83 (249.7)	600A-(2) #1-500 kcmil (50-240) 800A-(2) 500-750 kcmil (300-400)	136 (61.7)
P3BND (N-Frame)	800	600	45.98 (1167.9)	19.65 (499.1)	10.15 (257.8)	4.00 (101.6)	17.38 (441.5)	9.83 (249.7)	700A-(2) #1-500 kcmil (50-240) 800A-(3) 3/0-400 kcmil (95-185)	138 (62.6)
P3BLAP (TRI-PAC)	400	600	45.89 (1165.6)	19.65 (499.1)	10.15 (257.8)	4.00 (101.6)	13.80 (350.5)	9.83 (249.7)	225A-(1) #6-350 kcmil (16-185) 400A-(1) #4-250 kcmil and (1) 3/0-600 kcmil (25-120 and 95-300)	96 (43.5)
P3BLCL	400	600	41.86 (1063.2)	19.65 (499.1)	10.15 (257.8)	4.00 (101.6)	13.80 (350.5)	9.83 (249.7)	(1) #4-250 kcmil (25-120) and (1) 3/0-600 kcmil (95-300)	88 (39.9)
Fusible Plug-In Units										
P3F321RGH	30	240	14.72 (373.9)	13.92 (353.7)	8.46 (214.8)	3.85 (97.7)	7.95 (202.0)	5.66 (143.7)	Cu (1) #14-#3 (2.5-35)	32 (14.5)
P3F321RGV	30	240	15.85 (402.5)	14.03 (356.3)	8.46 (214.8)	3.85 (97.7)	6.72 (170.6)	5.66 (143.7)	Al (1) #12-#2 (3.2-35)	32 (14.5)
P3F361RGH	30	600	14.72 (373.9)	13.92 (353.7)	8.46 (214.8)	3.85 (97.7)	7.95 (202.0)	5.66 (143.7)	Cu (1) #14-#3 (2.5-35)	32 (14.5)
P3F361RGV	30	600	15.85 (402.5)	14.03 (356.3)	8.46 (214.8)	3.85 (97.7)	6.72 (170.6)	5.66 (143.7)	Al (1) #12-#2 (3.2-35)	32 (14.5)
P3F322RGH	60	240	14.88 (377.9)	17.92 (455.3)	8.37 (212.5)	3.85 (97.7)	11.95 (303.6)	5.66 (143.7)	Cu (1) #14-#3 (2.5-35)	40 (18.1)
P3F322RGV	60	240	19.85 (504.1)	14.16 (359.6)	8.37 (212.5)	3.85 (97.7)	6.84 (173.8)	5.66 (143.7)	Al (1) #12-#2 (3.2-35)	40 (18.1)
P3F362RGH	60	600	14.88 (377.9)	17.92 (455.3)	8.37 (212.5)	3.85 (97.7)	11.95 (303.6)	5.66 (143.7)	Cu (1) #14-1/0 (2.5-50)	40 (18.1)
P3F362RGV	60	600	19.85 (504.1)	14.16 (359.6)	8.37 (212.5)	3.85 (97.7)	6.84 (173.8)	5.66 (143.7)	Al (1) #12-1/0 (3.2-50)	40 (18.1)
P3F323RGH	100	240	14.88 (377.9)	17.92 (455.3)	8.37 (212.5)	3.85 (97.7)	11.95 (303.6)	5.66 (143.7)	Cu (1) #14-1/0 (2.5-50)	40 (18.1)
P3F323RGV	100	240	19.85 (504.1)	14.16 (359.6)	8.37 (212.5)	3.85 (97.7)	6.84 (173.8)	5.66 (143.7)	Al (1) #12-1/0 (3.2-50)	40 (18.1)
P3F363RGH	100	600	14.88 (377.9)	17.92 (455.3)	8.37 (212.5)	3.85 (97.7)	11.95 (303.6)	5.66 (143.7)	Cu (1) #4-250 kcmil (25-120)	40 (18.1)
P3F363RGV	100	600	19.85 (504.1)	14.16 (359.6)	8.37 (212.5)	3.85 (97.7)	6.84 (173.8)	5.66 (143.7)	Al (1) #4-250 kcmil (25-120)	40 (18.1)
P3F324RGH	200	240	17.42 (442.5)	21.98 (558.3)	8.52 (216.3)	3.85 (97.7)	15.44 (392.1)	6.80 (172.8)	Cu (1) #4-250 kcmil (25-120)	56 (25.4)
P3F324RGV	200	240	23.80 (604.5)	16.64 (422.8)	8.52 (216.3)	3.85 (97.7)	8.26 (209.8)	6.80 (172.8)	Al (1) #4-250 kcmil (25-120)	56 (25.4)
P3F364RGH	200	600	17.42 (442.5)	21.98 (558.3)	8.52 (216.3)	3.85 (97.7)	15.44 (392.1)	6.80 (172.8)	Cu (1) #4-600 kcmil (25-300)	56 (25.4)
P3F364RGV	200	600	23.80 (604.5)	16.64 (422.8)	8.52 (216.3)	3.85 (97.7)	8.26 (209.8)	6.80 (172.8)	Al (1) #4-600 kcmil (25-300)	56 (25.4)
P3F325R	400	240	48.85 (1242.1)	21.22 (539.0)	10.07 (255.8)	4.00 (101.6)	10.69 (271.5)	10.69 (271.5)	Cu/Al (1) 250-750 kcmil (127-380)	77 (34.9)
P3F365R	400	600	48.85 (1242.1)	21.22 (539.0)	10.07 (255.8)	4.00 (101.6)	10.69 (271.5)	10.69 (271.5)	Cu/Al (1) 250-750 kcmil (127-380)	77 (34.9)
P3F365HR	400	600	23.59 (599.2)	21.22 (539.0)	21.00 (533.4)	4.00 (101.6)	10.69 (271.5)	10.69 (271.5)	Cu/Al (2) 3/0-250 kcmil (85-127)	81 (36.7)
P3F326R	600	240	48.90 (1242.1)	26.31 (668.3)	10.59 (270.0)	4.00 (101.6)	13.16 (334.3)	13.16 (334.3)	Cu/Al (2) #2-600 kcmil (35-300)	82 (37.1)
P3F366R	600	600	48.90 (1242.1)	26.31 (668.3)	10.59 (270.0)	4.00 (101.6)	13.16 (334.3)	13.16 (334.3)	Cu/Al (3) #2-600 kcmil (25-300)	82 (37.1)
P3F327R	800	240	48.90 (1242.1)	26.31 (668.3)	10.59 (270.0)	4.00 (101.6)	13.16 (334.3)	13.16 (334.3)	Cu/Al (3) #2-600 kcmil (25-300)	108 (49.0)
P3F367R	800	600	48.90 (1242.1)	26.31 (668.3)	10.59 (270.0)	4.00 (101.6)	13.16 (334.3)	13.16 (334.3)	Cu/Al (3) #2-600 kcmil (25-300)	108 (49.0)

6.2

Low Voltage Busway

Pow-R-Way

Pow-R-Way Single Bolt per Joint, 600–5000A and Pow-R-Way II (Single Bolt per Busbar, 225–400A)



Typical Pow-R-Way Plug-In Straight Length



Typical Pow-R-Way Feeder Straight Length

6

Pow-R-Way Busway

Product Description

Plug-In Busway

- Pow-R-Way II plug-in busway
225–400A copper
225–400A aluminum
- Pow-R-Way plug-in busway
600–4000A copper
600–4000A aluminum

Straight sections of plug-in busway are available in 2 ft (0.6m) incremental lengths from a 2 ft (0.6m) minimum to a 10 ft (3m) maximum.

Feeder Busway

- Pow-R-Way II indoor feeder busway
225–400A copper
225–400A aluminum
- Pow-R-Way indoor or outdoor feeder busway
600–5000A copper
600–4000A aluminum

Straight sections of indoor and outdoor feeder busway are available in 1/8-inch (3.2 mm) increments from an 1/8-inch (457 mm) minimum to 10 ft (3m) maximum.

Plug-In Units

A full family of busway plug-in units is available. Standard plug-in units include fusible or circuit breaker protection.

Contents

Description

	<i>Page</i>
Pow-R-Way Busway	
Product Selection	V2-T6-33
Accessories	V2-T6-35
Technical Data and Specifications	V2-T6-35

Standards and Certifications

Pow-R-Way and Pow-R-Way II busways meet the requirements of UL, CSA and NEMA.

Additional Information

Technical Data: AD30-560



Product Selection

General Information

- Determine the total footage, all fittings, and accessories for entire busway run. Price the total footage by type and system requirements. Round footage up to the nearest foot. Add the fabrication charge for the fittings. Add any additional accessories required for the total price of the busway run
- When pricing a cable tap box or a weatherhead, include the price of 4 ft (1.2m) of feeder busway to the fabrication charge
- Cable tap boxes include 1/0 to 600 kcmil lugs. For additional lugs, larger lugs, or compression type lugs, refer to Eaton's busway
- Additional fittings on **Page V2-T6-39**

Plug-In

- Straight sections of plug-in busway are available in 2 ft (0.6m) increments from a 2 ft (0.6m) minimum to a 10 ft (3m) maximum

Feeder

- Straight sections of feeder busway are available in 1/8-inch (3.2 mm) increments from 16 in (406 mm) minimum to 10 ft (3m) maximum

Hangers

- The busway price includes one horizontal hanger per 10 ft (3m) of busway. All vertical hangers and any additional horizontal hangers should be added to the total price

Circuit Breaker Plug-In Units

Pow-R-Way Bus Plug



Pow-R-Way Bus Plug (Open View)



Circuit Breaker Plug-In Units

Breaker Frame	Ampere Rating	Plug-in Enclosure Catalog Number	100% Neutral Stab Catalog Number	50% Internal Ground Stab Catalog Number
ED, EHD, FDB, FD, HFD, FDC, EDH, EDC	15–150	IBPFD	PWN110 (15–110A) PWN150 (125–250A)	PIGS104
JDB, JD, HJD, JDC	70–250	IBPJD	PWN250 (125–250A)	PIGS104
KDB, KD, HKD, KDC	100–400	IBPKD	PWN400 (150–400A)	PIGS104
LDB, LD, HLD, LDC	300–600	IBPLD	PWN600 (300–600A)	PIGS208
MDL, HMDL	400–800	IBPMD	PWN800 (400–800A)	PIGS608
FB TRI-PAC®	15–100	IBPFBP	PWN110 (15–100A)	PIGS104
LA TRI-PAC	125–400	IBPLAP	PWN400 (125–400A)	PIGS104
NB TRI-PAC	500–800	IBPNBP	PWN800 (500–800A)	PIGS208
FCL Current Limit-R	15–100	IBPFCL	PWN110 (15–110A)	PIGS104
LCL Current Limit-R	125–400	IBPLCL	PWN400 (125–400A)	—

- Refer to **Page V2-T6-22** for breaker data; for reference only

Note: The enclosure, circuit breaker, neutral and ground are ordered and shipped assembled. See **Page V2-T6-14** for plug assembled style number configuration.

- Bolt-on units require a power take-off at the rating of the busway
- Also available in bolt-on unit configuration

Fusible Plug-In Units

Fusible ITAP

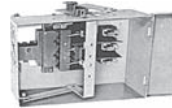

Fusible Switch Horsepower Ratings

Ampere Rating	240V		480V		600V	
	NEC Standard	Maximum	NEC Standard	Maximum	NEC Standard	Maximum
30	3	7-1/2	5	15	7-1/2	20
60	7-1/2	15	15	30	15	50
100	15	30	25	60	30	75
200	25	60	50	125	60	150
400	50	125	100	250	125	350
600	75	200	150	400	200	500
800	100	250	200	500	250	500

6.2

Low Voltage Busway

Pow-R-Way

6

Fusible Plug-In Units

Ampere Rating					Class R Fuse Clips (If Required)	
	Enclosure 600V Catalog Number	Enclosure 240V Catalog Number	100% Neutral Stab Catalog Number	50% Internal Ground Stab Catalog Number	600V Catalog Number	240V Catalog Number
30	ITAP361	ITAP321	PWN110	PIGS104	RFK161	RFK121
60	ITAP362	ITAP322	PWN110	PIGS104	RFK262	RFK222
100	ITAP363	ITAP323	PWN110	PIGS104	RFK464	RFK464
200	ITAP364	ITAP324	PWNF250	PIGS208	RFK464	RFK464
400	ITAP365	ITAP325	PWN400	PIGS208	RFK666	RFK666
600	ITAP366	ITAP326	PWN600	PIGS208	RFK666	RFK666
800	ITAP367	ITAP327	PWN800	PIGS208	—	—

- Fuses are not included
 - Mechanical lugs are provided. If compression lugs are required, the size must be specified
 - Plug-in unit, neutral and ground are ordered and shipped assembled
- Note:** See **Page V2-T6-14** for plug assembled style number configuration.
- H-Fuse clips are supplied as standard
 - Bolt-on units require a power take-off at the rating of the busway
- Bolt-on units are available
 - If R-Fuse clips are required, add an "R" to the end of the catalog number (30–600A only)

Special Industry Fusible Plug-In Units

Ampere Rating	Enclosure 600V Catalog Number	100% Neutral Stab Catalog Number	50% Internal Ground Stab Catalog Number	Terminal Kit Compression Lugs		
				Number Per Phase	Wire Size	Catalog Number
30	ITAP361H	①	①	1	1–#12 to #10	CTK30SC
60	ITAP362H	①	①	1	1–#8	CTK60SC
100	ITAP363H	①	①	1	1–#4	CTK100SC
200	ITAP364H	①	①	1	1–2/0	CTK200BSC
400	ITAP365H	①	①	1	1–750 kcmil	CTK400SPW
600	ITAP366H	①	①	2	2–500 kcmil	CTK600DPM

- Fuses are not included
 - Grounding compression lug included on 200A and above. Lugs are ordered and shipped separately; fuses are not included
- H-Fuse clips are supplied as standard
 - If J- or R-Fuse clips are required, order by description

Pow-R-Way Plug-In Cable Tap Box Units

Ampere Rating	Enclosure 600V Catalog Number	100% Neutral Stab Catalog Number	50% Internal Ground Stab Catalog Number
225	IPTB225	PWN225	PIGS208
400	IPTB400	PWN400	PIGS208
600	IPTB600	PWN600	PIGS208
1000	IPTB1000	PWN1000	PIGS208

Note

① Grounds and neutrals must be factory assembled. Order by description. See **Page V2-T6-10**.

Accessories

Accessories and Renewal Parts

Description	Catalog Number
Indoor joint cover	PWIJC
Outdoor joint cover	PWOJC
Hookstick kit— 8–14 ft (2.4–4.3m)	HS8-14
Joint puller	PWJP

Technical Data and Specifications

The following systems are available:

- Three-phase, three-wire
- Three-phase, three-wire, with 50% internal ground
- Three-phase, four-wire (100% neutral)
- Three-phase, four-wire (100% neutral) with 50% internal ground
- All three-wire systems have a maximum voltage rating of 600V and all four-wire systems have a maximum of 347/600V

Note: The Pow-R-Way bus housing is NOT suitable for use as ground.

Short-Circuit Withstand Ratings—rms Symmetrical Amperes for Copper Pow-R-Way Plug-In and Feeder Busway

Ampere Rating	3-Cycle Copper Plug-In	3-Cycle Copper Feeder
225	18,000	18,000
400	25,000	25,000
600	50,000	75,000
800	50,000	75,000
1000	100,000	100,000
1200	100,000	100,000
1350	100,000	100,000
1600	100,000	100,000
2000	100,000	100,000
2500	150,000	150,000
3000	150,000	150,000
4000	200,000	200,000
5000	—	200,000

Short-Circuit Withstand Rating—rms Symmetrical Amperes for Aluminum Pow-R-Way Plug-In and Feeder Busway

Ampere Rating	3-Cycle Aluminum Plug-In	3-Cycle Aluminum Feeder
225	18,000	18,000
400	25,000	25,000
600	50,000	75,000
800	100,000	100,000
1000	100,000	100,000
1200	100,000	100,000
1350	100,000	100,000
1600	100,000	100,000
2000	100,000	100,000
2500	150,000	150,000
3000	150,000	150,000
4000	200,000	270,000
5000	—	—

Typical Pow-R-Way Joint (Single Bolt Construction, One Bar per Phase, See AD 30-560)

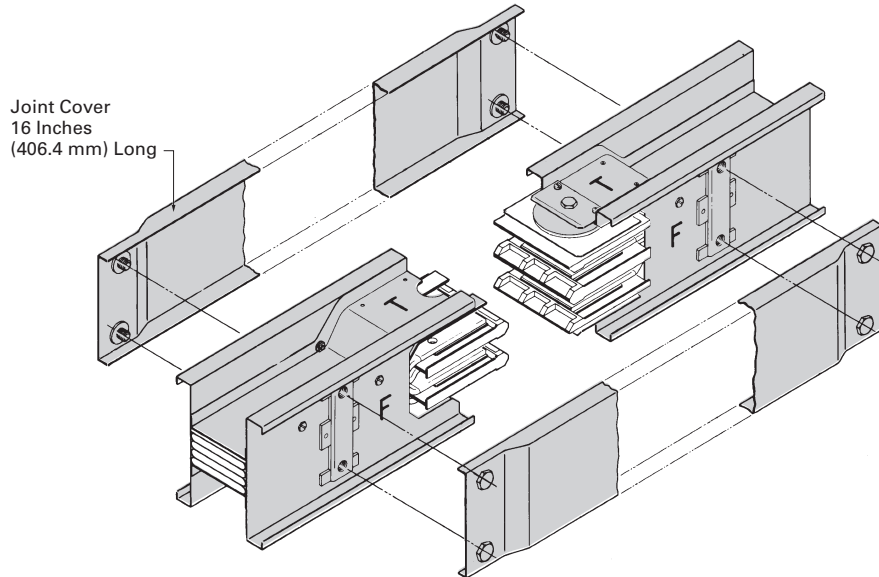

6.2

Low Voltage Busway

Pow-R-Way



Typical Pow-R-Way II Plug-In Straight Length

Typical Pow-R-Way II Joint (Single Bolt per Busbar, Pow-R-Way II)

6

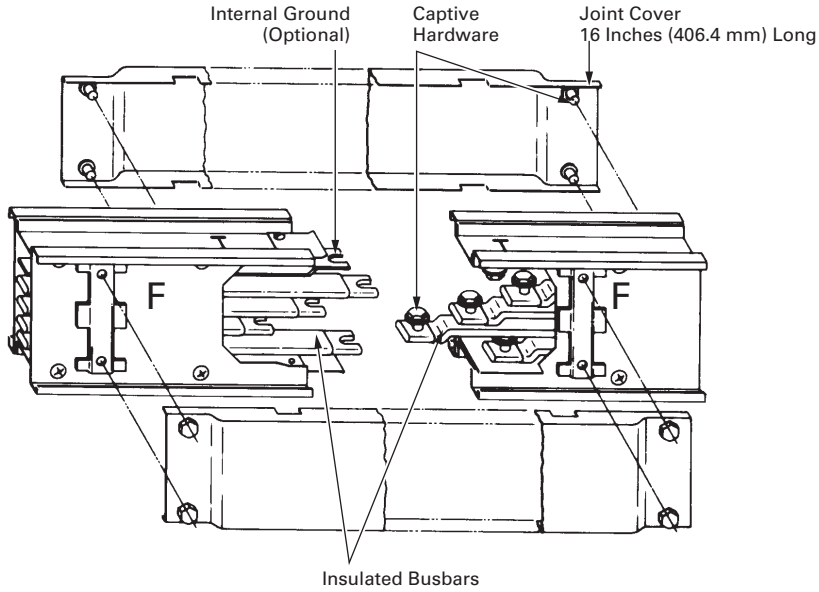

Bus Plug Receptacle



Contents

Description

Description	Page
100A Busway	
Options and Accessories	V2-T6-38
Technical Data and Specifications	V2-T6-39

100A Busway

Product Description

Plug-In Busway

- 100A copper
- Straight sections of plug-in busway
- Three-phase, three-wire; three-phase, four-wire; and single-phase, three-wire applications

Application Description

Eaton 100A busway is an alternative to cable in supplying small blocks of power for the normal commercial and industrial power systems. 100A busway is practical for small shops, laboratories, classrooms and light manufacturing.

Product Selection

Busway

Description	Three-Phase, Three-Wire 600V Maximum Catalog Number	Three-Phase, Four-Wire FN 277/480V Catalog Number	Single-Phase, Three-Wire 120/240V Catalog Number
Copper (Includes 50% Internal Ground Bar)			
10 ft (3m)	CST13G	CST14G	CST13NG
5 ft (1.5m)	CST135G	CST145G	CST13N5G
3 ft (0.9m)	CST133G	CST143G	CST13N3G
2 ft (0.6m)	CST132G	CST142G	CST13N2G
1 ft (0.3m)	CST131G	CST141G	CST13N1G
Elbows 10 x 10 in (254.0 x 254.0 mm)			
Forward	CFE13G	CFE14G	CFE13NG
Rearward	CRE13G	CRE14G	CRE13NG
Upward	CUE13G	CUE14G	CUE13NG
Downward	CDE13G	CDE14G	CDE13NG

Cable Tap Boxes

Type	Three- or Four-Wire Catalog Number	Ground (If Required) Catalog Number
Plug-in	PIB14	PIGS100
End (R or L)	EB14	GL100
Center	CBIB14G	Included

6.3

Low Voltage Busway

100A Busway

6

Fusible Plug-In Units

Voltage Rating	Ampere Rating	Fusible Enclosure Catalog Number	Ground (If Required) Catalog Number
240	30	FAN321	PIGS100
240	60	FAN322	PIGS100
240	100	FAN323	PIGS100
600	30	FAN361	PIGS100
600	60	FAN362	PIGS100
600	100	FAN363	PIGS100

Circuit Breakers for Plug-In Units

Breaker Frame	Ampere Rating	Circuit Breaker Enclosure Catalog Number	Receptacle Enclosure Catalog Number	Ground (If Required) Catalog Number	External Handle (Required for Hook-Stick Operation) Catalog Number
QUICKLAG, HQP	15–50	PINQP	LCNQP	PIGS100	HMQP
FD, EHD, FDB	15–100	PINFD	LCNFD	PIGS100	HMFD

Options and Accessories

100A Busway Plug-In Units

Plug-in units for 100A busway are available with or without overcurrent protection. All plug-in units include a neutral stab and are suitable for three-phase, three-wire, and three-phase, four-wire applications.

The PINQP circuit breaker enclosures and the LCNQP and LCNFD receptacle enclosures are all suitable for single-phase, three-wire applications. Ground stabs are available for field installation.

Fusible Units

Fusible units are available for 30, 60 and 100A service for 240 or 600V.

Circuit Breaker Units

If you are using circuit breaker units, the load must be distributed evenly among A, B and C phases. To accomplish this, distribute the load evenly among single-, two- and three-pole breakers. Available are QUICKLAG® “HQP” circuit breaker units for 50A–240V maximum service, “EHD, FDB and FD” circuit breakers for 100A–600V maximum service.

External Handle Operating Mechanism

An external operating mechanism is attached on top of the breaker switch for hookstick or chain operation. This is available for all circuit breakers.

Receptacle Enclosures

The receptacle enclosures (loadcenters) include space for three breaker poles and provisions for one, two or three conventional, single-gang outlets, and blank covers to fill unused spaces. Include neutral stab. Do not include breakers, outlets or wiring.

The enclosure, circuit breaker (if required) and ground are ordered separately and shipped unassembled. If the unit is to be factory assembled, please indicate on the order, add 15% to the total price, and allow additional time for shipment. For circuit breaker selection, see **Page V2-T6-22**.

Accessories

Item	Catalog Number
End closer	EC1
Outlet cover	OC1
Edgewise hanger	EH1
“C” clamp hanger	FH1
Slip-on wall flange	WF1

Note

The above items can be used with or without ground, three-wire or four-wire.

Accessories

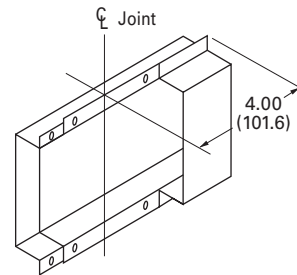

End Closers—EC1

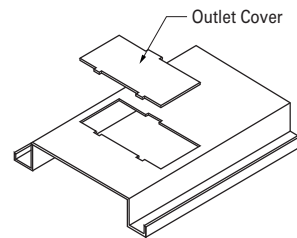

Replacement Outlet Cover—OC1

Hangers

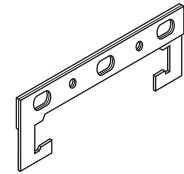

“C” Clamp—FH1

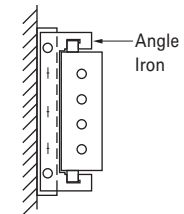

Wall Mounted

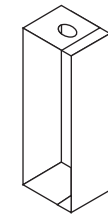

Edgewise—EH1

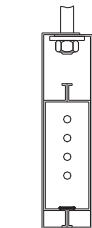

Edge Mounted

Technical Data and Specifications

Electrical conductors are silver-plated round copper rods. A 50% internal ground bar is supplied as standard. Busway with ground will match existing busway without ground. The housing is formed from two channels of 20-gauge steel riveted together in a solid assembly and painted ANSI 6.1.

Conductor joints are made by means of boltless pressure clips that require no assembly or adjustment by the installer. The busbars are firmly supported by molded insulators on the alternate side of the busway.

100A Busway and Fittings

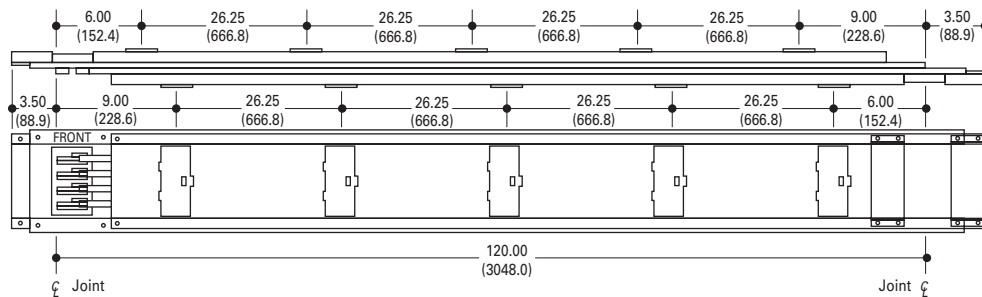

Typical 100A Busway, Straight Length

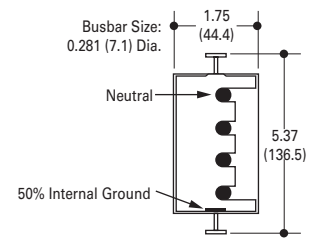

Typical Cross-Section

10.00 (254.0) x 10.00 (254.0)

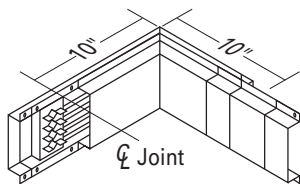

Forward Elbow

10.00 (254.0) x 10.00 (254.0)

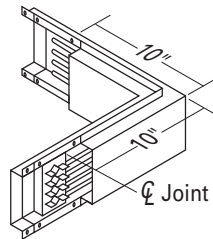

Rearward Elbow

10.00 (254.0) x 10.00 (254.0)

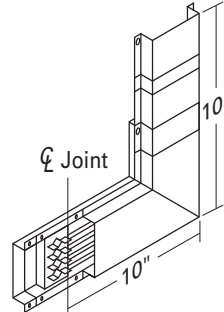

Upward Elbow

10.00 (254.0) x 10.00 (254.0)

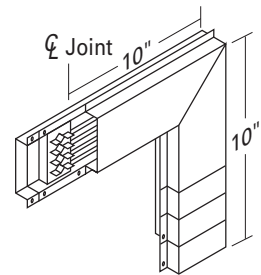

Downward Elbow