

# Installation and Service Manual for Residential Series EVSE (Electric Vehicle Supply Equipment)



## Contents

Description	Page
<b>Installation guide</b> . . . . .	2
Important safety instructions—please read . . . . .	2
Symbols and definitions . . . . .	2
About the charging station . . . . .	2
Installation . . . . .	4
Installing the electrical service . . . . .	5
Installing to the premise . . . . .	6
Termination and configuration . . . . .	16
Confirming installation and first use . . . . .	16
Specifications . . . . .	17
Troubleshooting . . . . .	18
<b>Service manual</b> . . . . .	19
Opening unit . . . . .	19



*Powering Business Worldwide*

## Installation guide

### Important safety instructions—please read

---

#### **⚠ WARNING ELECTRICAL**

**THIS EQUIPMENT SHOULD BE INSTALLED, ADJUSTED, AND SERVICED BY QUALIFIED ELECTRICAL PERSONNEL FAMILIAR WITH THE CONSTRUCTION AND OPERATION OF THIS TYPE OF EQUIPMENT AND THE HAZARDS INVOLVED. FAILURE TO OBSERVE THIS PRECAUTION COULD RESULT IN DEATH OR SEVERE INJURY.**

**READ THIS MANUAL THOROUGHLY AND MAKE SURE YOU UNDERSTAND THE PROCEDURES BEFORE YOU ATTEMPT TO OPERATE THIS EQUIPMENT. THE PURPOSE OF THIS MANUAL IS TO PROVIDE YOU WITH INFORMATION NECESSARY TO SAFELY OPERATE, MAINTAIN, AND TROUBLESHOOT THIS EQUIPMENT. KEEP THIS MANUAL FOR FUTURE REFERENCE.**

**DO NOT USE THIS PRODUCT IF THE EV CABLE IS FRAYED, HAS DAMAGED INSULATION, OR ANY OTHER SIGN OF DAMAGE.**

**DO NOT USE THIS PRODUCT IF THE ENCLOSURE OR THE EV CONNECTOR IS BROKEN, CRACKED, OPEN, OR SHOWS ANY OTHER INDICATION OF DAMAGE.**

**INTENDED FOR USE WITH PLUG-IN ELECTRIC VEHICLES ONLY. PREMISE VENTILATION NOT REQUIRED.**

**THE INFORMATION CONTAINED IN THIS MANUAL IS SUBJECT TO CHANGE WITHOUT NOTICE.**

---

## Symbols and definitions

---

#### **⚠ WARNING ELECTRICAL**

**THIS SYMBOL INDICATES HIGH VOLTAGE. IT CALLS YOUR ATTENTION TO ITEMS OR OPERATIONS THAT COULD BE DANGEROUS TO YOU AND OTHER PERSONS OPERATING THIS EQUIPMENT. READ THE MESSAGE AND FOLLOW THE INSTRUCTIONS CAREFULLY.**

---

---

#### **⚠ CAUTION**

**INDICATES A POTENTIAL HAZARDOUS SITUATION THAT, IF NOT AVOIDED, CAN RESULT IN MINOR TO MODERATE INJURY, OR SERIOUS DAMAGE TO THE EQUIPMENT. THE SITUATION DESCRIBED IN THE CAUTION MAY, IF NOT AVOIDED, LEAD TO SERIOUS RESULTS. IMPORTANT SAFETY MEASURES ARE DESCRIBED IN CAUTION (AS WELL AS WARNING).**

---

---

#### **⚠ IMPORTANT**

**INDICATES A PARTICULAR ITEM OR INSTRUCTION THAT IS IMPORTANT TO CONSIDER.**

---

Save these instructions.

## Definitions

**AC—Alternating current.** The type of power available in most buildings and on utility poles. The EVSE charging station protects users and vehicles by allowing AC power to flow through it to the vehicle. The vehicle then converts the AC to DC (direct current) to charge the traction battery.

**ALC—Available line current.** The EVSE charging station tells the vehicle through the J1772™ connector's pilot pin how much current (in amperes) it is allowed to pull on the circuit. This allows the car to not exceed the circuit's maximum current rating.

**EVSE—Electric Vehicle Supply Equipment.** EVSE is a general term used for all of the equipment used to supply electricity to the car, such as the Eaton EVSE charging station.

**GFCI—Ground fault circuit interrupter.** GFCI protects users from faults involving leakage currents going to ground, rather than the proper return path of the circuit.

**J1772—**The SAE Recommended Practice for conductive charging of hybrid and electric vehicles. This standard spells out the physical dimensions of the J1772 connector and the pilot communication between the plug-in vehicle and the EVSE.

**Pilot—**The signal through the J1772 connector. This signal tells both the vehicle and the EVSE when both are ready to charge and how much current it is allowed to pull. This signal is a SAE standard.

**Plug session—**The time during which the EVSE is plugged into a vehicle. It starts when the J1772 connector is plugged in and ends when the same connector is unplugged.

**SAE—Society of Automotive Engineers.** The group that organizes and leads committees of transportation experts to create standards, such as J1772, for the transportation industry.

**Traction battery—**The large battery on a plug-in electric vehicle that is used to store and release energy for propulsion. This is different from the 12 V battery that is used to start the vehicle initially and run accessories such as the radio.

**UI—User Interface.** The user interface part of the unit.

**TB—Terminal Block.** The point at which the incoming field power will be terminated in the EVSE unit.

**ADA—Americans with Disabilities Act.**

## About the charging station

Eaton's Electric Vehicle Supply Equipment (EVSE) charging station is compatible with the Society of Automotive Engineers J1772 standard for charging plug-in hybrid and all-electric vehicles.

The charging station has several safety features:

- Protects users with interlocked power; the cable and pins have no power on them until the connector is safely plugged into a vehicle
  - Protects users from temporary faults and automatically resets so no user interaction is needed
- Note:** Automatic Reset feature must be enabled during installation—see **page 10** for more information.
- Instructs the vehicle on how much current to draw and keeps the upstream circuit protection from “nuisance tripping”
  - See “Specifications” on **page 17** for more details

### Moving, transporting, and storage instructions

Store this unit indoors and in its original packaging until it is ready to be installed. Storage temperature should be between -30 °C and 80 °C. When moving or lifting the unit, always grasp the unit enclosure. Never attempt to lift, move, or carry the unit by the EV cable. Do not carry the unit by the cable hook assembly.

Improper storage or handling may cause damage to the unit.

### Before you begin

#### **⚠ WARNING ELECTRICAL**

**ONLY QUALIFIED PERSONNEL FAMILIAR WITH THE OPERATION AND CONSTRUCTION OF THIS EQUIPMENT SHOULD INSTALL, ADJUST, MODIFY, AND SERVICE THIS EQUIPMENT. FAILURE TO FOLLOW THE INSTRUCTIONS COULD RESULT IN SEVERE BODILY INJURY OR DEATH.**

#### **⚠ IMPORTANT**

**THE USER IS RESPONSIBLE FOR CONFORMING TO ALL LOCAL AND NATIONAL ELECTRICAL CODES AND STANDARDS APPLICABLE IN THE JURISDICTION IN WHICH THIS EQUIPMENT IS INSTALLED.**

**Table 1. Replacement Parts**

<b>Part</b>	<b>Part Number</b>
Connector, 25-foot cable, and strain relief kit (16 A)	<b>EV2516CCKIT</b>
Connector, 25-foot cable, and strain relief kit (16 A resi)	<b>EV2520CCKIT</b>
Connector, 25-foot cable, and strain relief kit (30 A resi)	<b>EV2530CCKIT</b>
EVSE Level 1 and Level 2 advanced cord management	<b>EVADVCORDMGT</b>
EVSE Level 1 and Level 2 basic cord management	<b>EVBASCORDMGT</b>
EVSE Level 1 and Level 2 residential polycarbonate bottoms (2 pieces)	<b>EVCAPBB</b>
EVSE Level 1 and Level 2 residential polycarbonate top	<b>EVCAPTB</b>
Level 1 120 V contactor (16 A and 30 A)	<b>EVCNTR30120</b>
Level 2 240 V contactor (16 A and 30 A)	<b>EVCNTR30240</b>
LED light	<b>EVLED</b>
LED ON/OFF pushbutton	<b>EVLEDPB</b>
Level 1 120 V protection and control board (resi 20 MA hardwired)	<b>EVPCB12020M</b>
Level 1 120 V protection and control board (resi 5 MA cord con)	<b>EVPCB1205M</b>
Level 2 240 V protection and control board (resi 20 MA hardwired)	<b>EVPCB24020M</b>
Level 2 240 V protection and control board (resi 5 MA cord con)	<b>EVPCB2405M</b>
Pilot light: green	<b>EVPLGREEN</b>
Pilot light: red	<b>EVPLRED</b>
Receptacle (20 A single)	<b>EVREC20</b>
User interface (residential)	<b>EVUIB</b>
LED light	<b>MPLEDCR</b>
20 A, 5 MA GFI cable in/out breaker	<b>QCG1020</b>

### ADA standards for accessible design

It is very important to consider all standards for accessible design for Americans with disabilities when choosing the location and placement of all Electric Vehicle Supply Equipment. The following is a direct excerpt from the 2010 ADA Standards for Accessible Design (<http://www.ada.gov/regs2010/2010ADAStandards/2010ADAstandards.htm#c3>):

*The Department of Justice published revised regulations for Titles II and III of the Americans with Disabilities Act of 1990 ("ADA") in the Federal Register on September 15, 2010. These regulations adopted revised, enforceable accessibility standards called the 2010 ADA Standards for Accessible Design ("2010 Standards") or ("Standards"). The 2010 Standards set minimum requirements—both scoping and technical—for newly designed and constructed or altered state and local government facilities, public accommodations, and commercial facilities to be readily accessible to and usable by individuals with disabilities. Adoption of the 2010 Standards also establishes a revised reference point for Title II entities that choose to make structural changes to existing facilities to meet their program accessibility requirements; and it establishes a similar reference for Title III entities undertaking readily achievable barrier removal. The Department has assembled this online version of the official 2010 Standards to increase its ease of use. This version includes:*

*2010 Standards for State and Local Government Facilities Title II and 2010 Standards for Public Accommodations and Commercial Facilities Title III.*

*The Department has assembled into a separate publication the revised regulation guidance that applies to the Standards. The Department included guidance in its revised ADA regulations published on September 15, 2010. This guidance provides detailed information about the Department's adoption of the 2010 Standards, including changes to the Standards, the reasoning behind those changes, and responses to public comments received on these topics. The document, Guidance on the 2010 ADA Standards for Accessible Design, can be downloaded from:*

<http://www.ada.gov>

*For information about the ADA, including the revised 2010 ADA regulations, please visit the Department's website: [www.ADA.gov](http://www.ADA.gov); or, for answers to specific questions, call the toll-free ADA Information line at 800-514-0301 (voice) or 800-514-0383 (TTY).*

## Installation

### Choosing a location

#### ⚠ IMPORTANT

**THINGS TO CONSIDER BEFORE CHOOSING A LOCATION TO MOUNT THE UNIT:**

- 1. LOCATION OF AN AVAILABLE MOUNTING SUPPORT—THE WALLMOUNT UNIT MUST BE ANCHORED INTO A MOUNTING SUPPORT SUCH AS A 2 X 4 STUD OR A SOLID CONCRETE WALL, USING MOUNTING HARDWARE THAT IS APPROPRIATE FOR THE SURFACE ON WHICH YOU ARE MOUNTING. DO NOT MOUNT THIS UNIT DIRECTLY TO A STUCCO/DRYWALL/WALLBOARD. SEE PAGE 6.**
- 2. LOCATION OF AN AVAILABLE ELECTRICAL SOURCE—POWER WIRES MUST BE RUN THROUGH AN APPROVED CONDUIT OR JACKET FROM THE CIRCUIT PANEL TO THE UNIT.**
- 3. LOCATION OF THE VEHICLE'S CHARGING INLET WHILE PARKED—THE UNIT MUST BE LOCATED SO THAT ITS RESPECTIVE CABLE LENGTH IS RIGHT-SIZED TO WHERE THE VEHICLE'S INLET IS FOR PLUG-IN WITHOUT UNDUE MANEUVERING.**

**Note:** These installation location recommendations are based upon general-purpose parking, trying to serve the most likely plug-in vehicle drivers. For specific parking, such as at home or in a captive fleet scenario where the user knows where the vehicle's inlet will be, locate the charging station appropriately.

Each plug-in electric vehicle manufacturer has a different location for where the charging inlet is located on the vehicle.

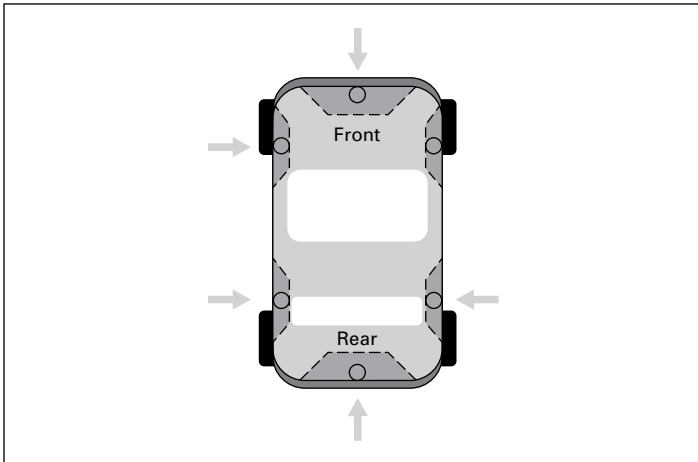

Figure 1. Vehicle Inlet Locations Differ by Manufacturer

In North America, it is recommended to install the charging station with a high focus on orienting the station toward the front and driver side of parking spaces. Suggestions for different types of parking layouts are illustrated below.

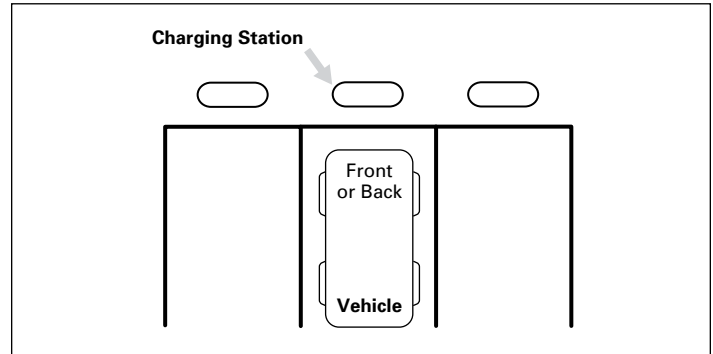

Figure 2. 90-Degree Parking

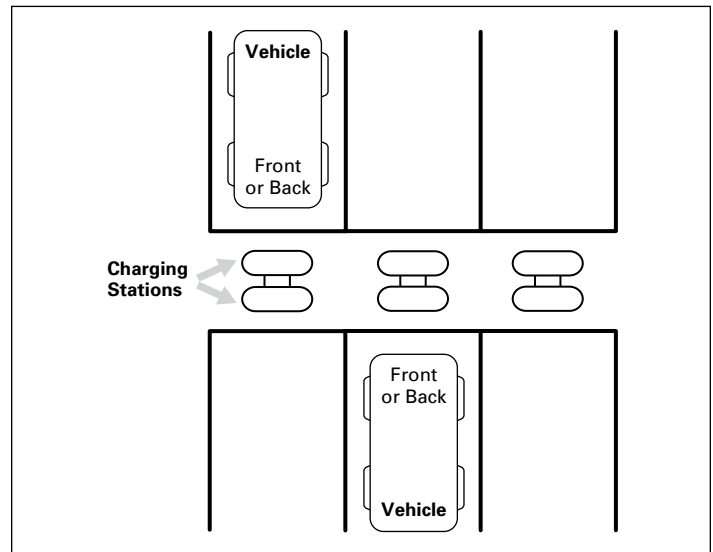

Figure 3. Back-to-Back Dual 90-Degree Parking

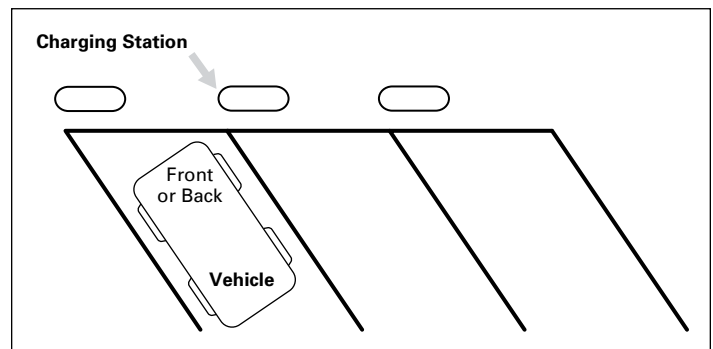

Figure 4. 45-Degree Parking

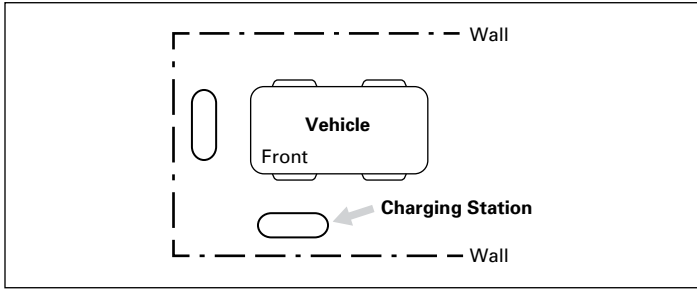

Figure 5. Parking Bay/Garage

**Note:** The wallmount style of charging station can come with a much longer cord, so in parking bays and garages, length of the cord is less of a problem for maintenance.

### Protecting the location

For outdoor installations, creative use of protective bollards and wheel stops are necessary. Vehicles can and will damage the units if left unprotected.

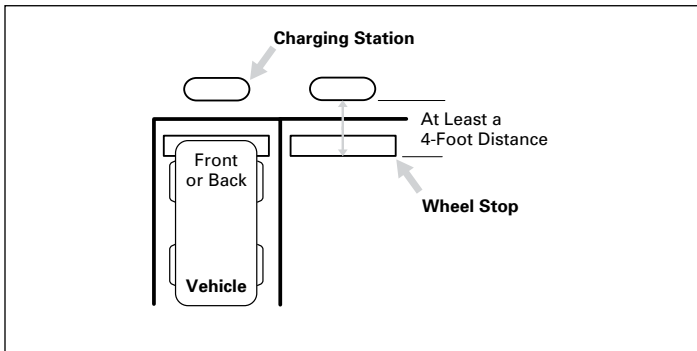

Figure 6. Protecting the Charging Station with Wheel Stops for General-Purpose Parking

Wheel stops are recommended to be installed at a minimum distance of 4 feet from the front of the charging station to the vehicle side of the wheel stop for general-purpose parking. This distance takes into account when larger vehicles, like the backing up of a pickup truck with a trailer hitch, back into such a space. For fleet customers with specific vehicles or for parking restricted to plug-in vehicles only, the wheel stop installation distance may be different.

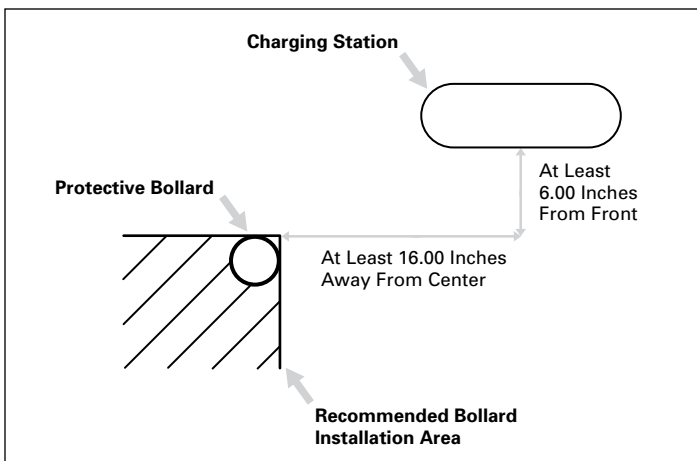

Figure 7. Protecting the Charging Station with Bollards

Protective bollards are recommended to be installed in the area defined by a distance of 16.00 inches from the front center of the charging station and 6.00 inches from the front of the unit. **See local jurisdiction requirements for actual specifications.**

## Installing the electrical service

### Checking the electrical requirements

The National Electrical Code®, Article 625.21, states “Overcurrent protection for feeders and branch circuits supplying electric vehicle supply equipment shall be sized for continuous duty and shall have a rating of not less than 125 percent of the maximum load of the electric vehicle supply equipment.” A load study of the location’s electrical service may be needed to determine the availability of adequate electrical service. Take the nameplate amperage rating of the charging station, and multiply by 125 percent for the minimum upstream circuit protection needed.

### Check in the installed jurisdiction for any other electrical requirements.

### Running the wires

Once the proper electrical overcurrent device has been installed, wire needs to be run from it to the charging station. For a typical installation, the only field wires will be for the incoming electrical service. If the EVSE unit has a remote management option, a standard CAT5/6 network cable or three-wire shielded cable typical for an RS485-type network could also need to be run to the unit.

## ⚠ WARNING ELECTRICAL

**LOCKOUT/TAGOUT ALL ELECTRICAL SOURCE CIRCUITS FEEDING THE UNIT(S) IN THE OPEN POSITION BEFORE BEGINNING WIRING OR TERMINATIONS. FAILURE TO FOLLOW THE INSTRUCTIONS COULD RESULT IN SEVERE BODILY INJURY OR DEATH.**

## ⚠ WARNING

**THIS UNIT IS RATED FOR INDOOR OR OUTDOOR INSTALLATION. IF THIS UNIT IS MOUNTED OUTDOORS, THE HARDWARE FOR CONNECTING THE CONDUITS TO THE UNIT MUST BE RATED FOR OUTDOOR INSTALLATION AND BE INSTALLED PROPERLY TO MAINTAIN THE PROPER “RAINTIGHT” RATING ON THE UNIT.**

## ⚠ IMPORTANT

**CONFIRM WITH THE LOCAL ELECTRICAL REQUIREMENTS FOR THE GAUGE, TEMPERATURE RATING, AND TYPE OF WIRE MATERIAL USED FOR THE OVERCURRENT RATING FOUND BELOW.**

## ⚠ IMPORTANT

**THE 30 A LEVEL 2 EVSE REQUIRES A DEDICATED 208/240 VAC, 40 A UPSTREAM TWO-POLE BREAKER.**  
**THE 16 A LEVEL 2 EVSE REQUIRES A DEDICATED 208/240 VAC, 20 A UPSTREAM TWO-POLE BREAKER.**  
**THE 16 A LEVEL 1 EVSE REQUIRES A DEDICATED 120 VAC, 20 A UPSTREAM SINGLE-POLE BREAKER.**  
**DO NOT USE GFCI BREAKERS. GFCI EXISTS IN EVSE.**

**Table 2. EVSE Overcurrent Ratings**

Style	Overcurrent Rating	Suggested Wire Gauge	Suggested Wire Type	Suggested Wire Temp Rating
<b>Wallmount or Pedestal</b>				
EVSE Level 2 16 A	20 A	12 AWG	Copper	75 °C
EVSE Level 2 30 A	40 A	8 AWG	Copper	75 °C
EVSE Level 1 16 A	20 A	12 AWG	Copper	75 °C

**EVSE wire installation**

Level 2 208/240 V with LED light

- (2) Hot
- (1) Neutral
- (1) Ground

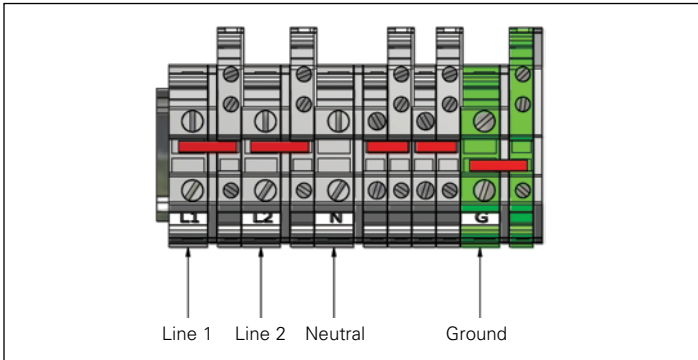

**Figure 8. 208/240 V with Optional LED Light**

Level 2 240 V without light

- (2) Hot
- (1) Ground

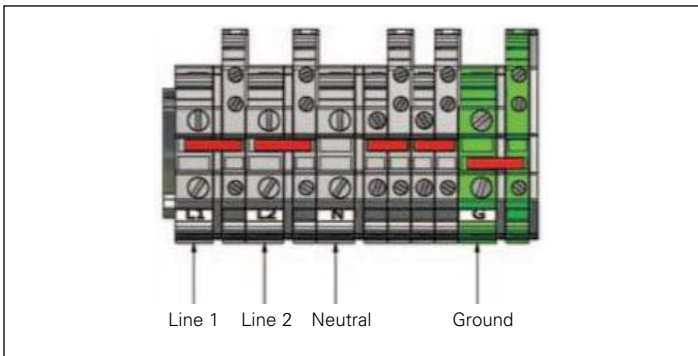

**Figure 9. 208/240 V without Optional LED Light**

Level 1 120 V with or without light

- (1) Hot
- (1) Neutral
- (1) Ground

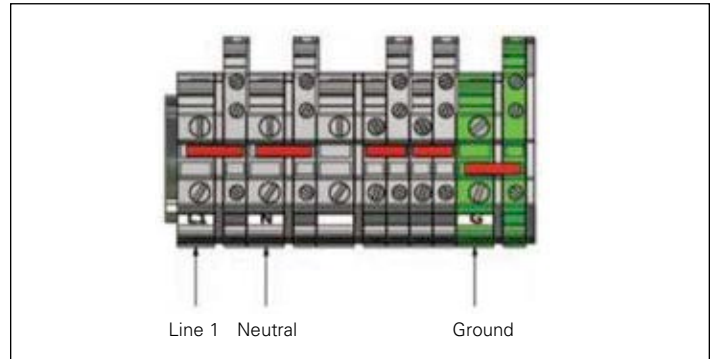

**Figure 10. 120 V**

**Installing to the premise**

There are two options available for feeding electricity to the EVSE—both methods require installing the EVSE onto a wall. One method of providing power to the EVSE is by hardwiring directly to the terminal; the other is by wiring a receptacle for the factory-installed plug from the EVSE (feed options must be configured at the time of purchase).

**Mounting to a wall—plug-and-cord connected**

**Preparing the site**

When a proper site has been chosen and the electrical service has been run to the location, you can begin installation.

**⚠ CAUTION**

**DO NOT MOUNT UNIT TO ONLY STUCCO/DRYWALL/WALLBOARD. DO NOT USE TOGGLE BOLTS, ZIP ANCHORS, NOR PLASTIC WALL ANCHORS MEANT FOR THESE SUBSTANCES BECAUSE THEY AND THE MATERIAL DO NOT HAVE THE STRENGTH NEEDED TO SUPPORT THE UNIT. THE UNIT MUST BE MOUNTED TO A SOLID WOOD SUPPORT, CONCRETE WALL, CONCRETE BLOCK WALL, OR EQUIVALENT.**

**Installation of receptacle pre-wire kit**

**Step 1:** Using the mounting plate as a template, mark the holes to be used for mounting. Make sure the mounting plate is level.

**Step 2:** Pre-drill mounting holes if mounting into a wood stud, or drill appropriate-sized holes into a solid wall for the type of anchor you will be using.

**Step 3:** Attach the mounting plate to the wall as shown in **Figure 11 on page 7**. If installing on a wood stud, use 1/4 x 3.00-inch long lag screws and washers, and ensure that the plate is mounted on the centerline of the stud. These should be galvanized or stainless steel for weather protection if mounting outdoors. If mounting onto a concrete, block, or brick wall, use an appropriate anchor for the type of wall on which you are installing the unit. Again, these should be appropriate for weather conditions if mounting outside.

**Step 4:** Mount the full charging station assembly by sliding the unit onto the wall plate. Once mounted, locate the cord and create a loop in order to find location for 30 A receptacle mounting. When the mounting location is determined, remove the charging station aside. Ensure that the NEMA® 6-50R receptacle is at least 48.00 inches from the finished floor. It is strongly advised to install a lockable “while in use” cover over the receptacle (not included).

**Step 5:** Mount the receptacle onto the wall inside the appropriate junction box for receptacle or mount externally on the outside surface of the wall. Use **Table 3** to determine the receptacle needed for your particular charging station.

**Step 6:** Plug the unit into the EVSETESTB unit to ensure proper function. Follow instruction on faceplate of test unit.

**Table 3. Receptacle Reference**

EVSE Type	Current	NEMA Receptacle Type Needed	Receptacle Description
Level 2 (without light)	16 A	6-20R	20 A, 250 V
Level 2 (without light)	30 A	6-50R	30 A, 250 V
Level 2 (with light)	16 A	14-20R	20 A, 125/250 V
Level 2 (with light)	30 A	14-50R	30 A, 125/250 V



**Figure 11. Unit and Mounting Plate**

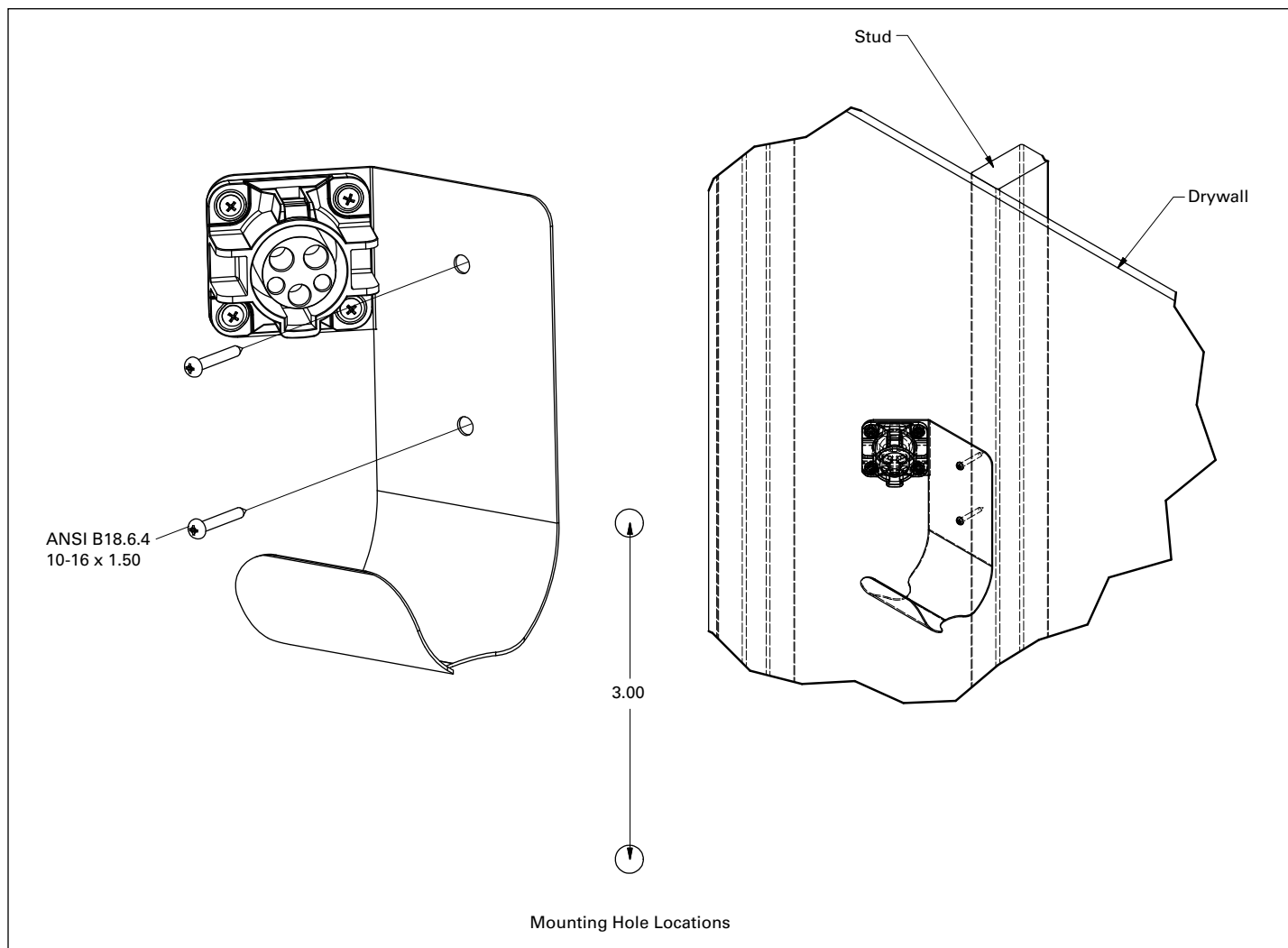

**Figure 12. Advanced Cord Management**

**Cord management bracket installation instructions**

If mounting bracket to a drywall surface:

1. Locate the center of the stud where you wish to install the bracket.
2. Using the cord management bracket as a template, precisely align the bracket along the center line of the stud and mark each of the four mounting holes.  
**Note:** Inserting a long screw through the mounting hole and pressing firmly into the drywall will create an adequate mark.
3. Using the marks made in Step 2 above, pre-drill a 1/8-inch hole at each of the four hole locations to a depth of 5/8-inch.
4. Attach the cord management bracket to the wall using four #10 x 1-1/2-inch Phillips pan head screws.

If mounting bracket to a plywood or similar surface:

1. Determine where you wish to install the bracket.
2. Mark screw hole locations (four locations on 1.00-inch centers).
3. Using the marks made in Step 2 above, pre-drill a 1/8-inch hole at each of the four hole locations to a depth of 5/8-inch.
4. Attach the cord management bracket to the wall using four #10 x 1-1/2-inch Phillips pan head screws.



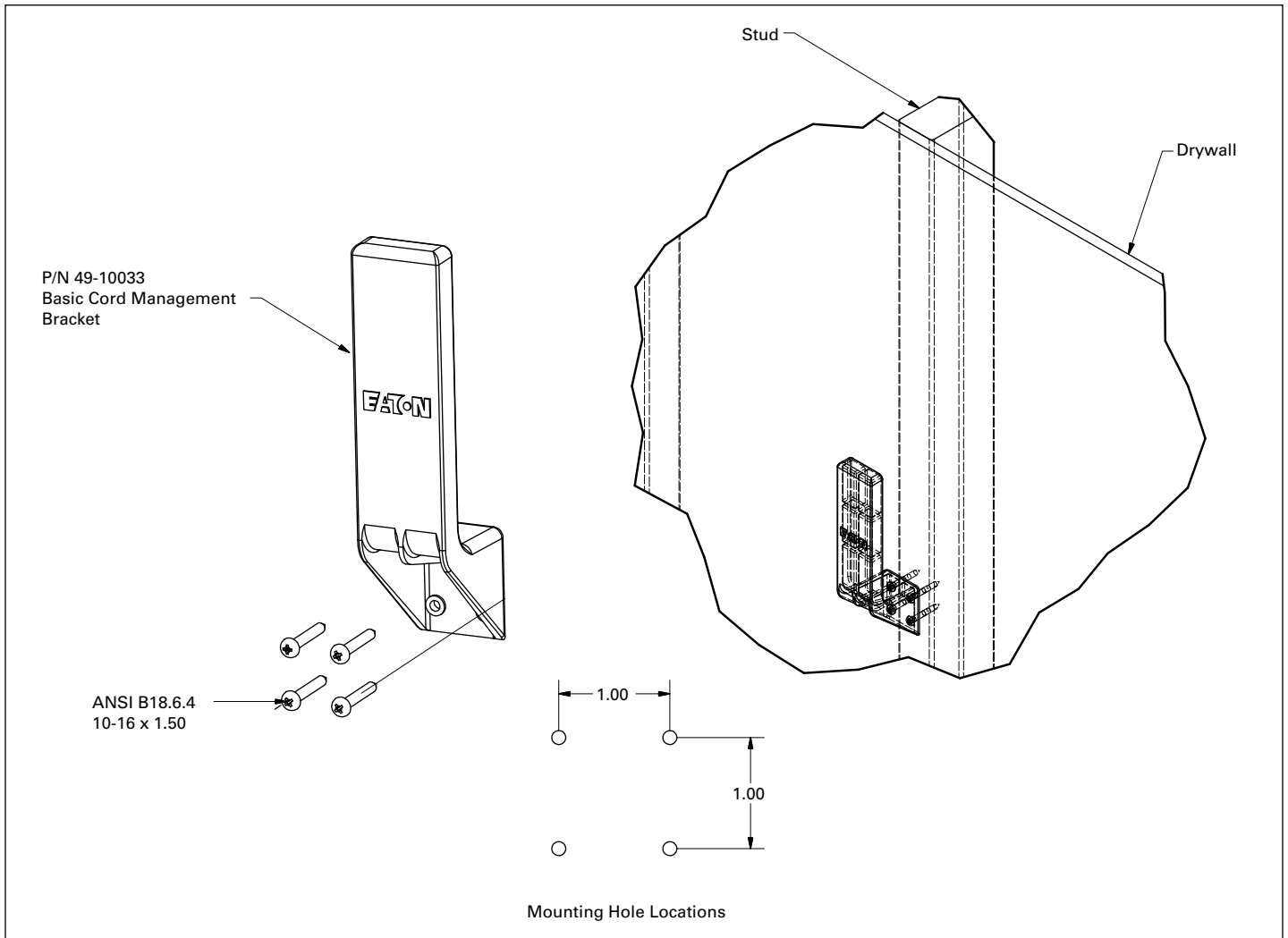

**Figure 13. Basic Cord Management**

### **Cord management bracket installation instructions**

If mounting bracket to a drywall surface:

1. Locate the center of the stud where you wish to install the bracket.
2. Using the cord management bracket as a template, precisely align the bracket along the center line of the stud and mark each of the four mounting holes.  
**Note:** Inserting a long screw through the mounting hole and pressing firmly into the drywall will create an adequate mark.
3. Using the marks made in Step 2 above, pre-drill a 1/8-inch hole at each of the four hole locations to a depth of 5/8-inch.
4. Attach the cord management bracket to the wall using four #10 x 1-1/2-inch Phillips pan head screws.

If mounting bracket to a plywood or similar surface:

1. Determine where you wish to install the bracket.
2. Mark screw hole locations (four locations on 1-inch centers).
3. Using the marks made in Step 2 above, pre-drill a 1/8-inch hole at each of the four hole locations to a depth of 5/8-inch.
4. Attach the cord management bracket to the wall using four #10 x 1-1/2-inch Phillips pan head screws.

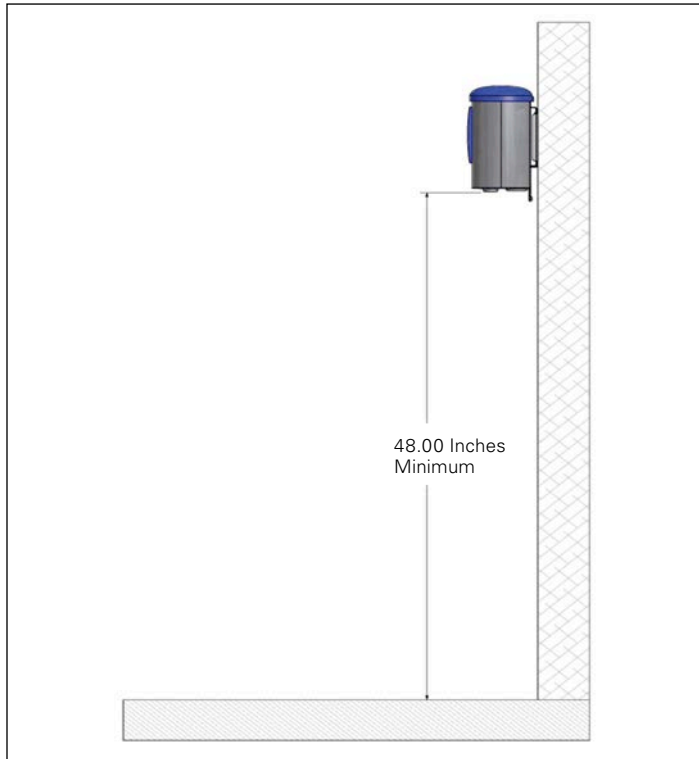

Figure 14. EVSE Recommended Wall Mounting Height

#### Mounting to a wall—hardwired

Once a proper site has been chosen and the electrical service has been run to the location, you can begin installation.

**Step 1:** Using the wallmount bracket template (not included), mark the holes to be used for mounting as well as the feeder conductor entry location. Make sure the template is level.

**Step 2:** Attach the wallmount bracket to the wall as shown in **Figure 15**. If installing on a wood stud, use 1/4 x 3.00-inch long lag screws and washers, and ensure that the plate is mounted on the centerline of the stud. These should be galvanized or stainless steel for weather protection if mounting outdoors. If mounting onto a concrete, block, or brick wall, use an appropriate anchor for the type of wall on which you are installing the unit. Again, these should be appropriate for weather conditions if mounting outside.

**Step 3:** Pull the incoming feed conductors through the wall to the appropriate location for entry through the charging station.

**Step 4:** Remove four #10–32 screws from the bottom of internal tray and slide stainless steel housing up to expose mounting flanges. Feed incoming conductors through bushing in internal tray, and place the charging station assembly onto the wallmount bracket over threaded studs. Secure the charging station to the wallmount bracket with #10 washers and nuts.

**Step 5:** Slide the EVSE housing down and secure with the #10–32 screws that were removed in Step 4.

**Mounting to a wall—hardwired, bottom conduit entry**

Once a proper site has been chosen and the electrical service has been run to the location, you can begin installation.

**Step 1:** Mark the holes to be used for mounting. Make sure the template is level.

**Step 2:** Attach the wallmount bracket to the wall as shown below. If installing on a wood stud, use 1/4 x 3.00-inch long lag screws and washers, insure plate is mounted on centerline of stud. These should be galvanized or stainless steel for weather protection if mounting outdoors. If mounting onto a concrete, block, or brick wall, use an appropriate anchor for the type of wall on which you are installing the unit. Again, these should be appropriate for weather conditions if mounting outside.

**Step 3:** Install conduit with feeder conductors to terminate into bottom of EVSE assembly (conduit entry location noted on template).

**Step 4:** Remove four #10–32 screws from the bottom of internal tray and slide stainless steel housing up to expose mounting flanges. Feed incoming conductors through bushing in internal tray and place EVSE assembly onto wallmount bracket over threaded studs. Secure EVSE to wallmount bracket with #10 washers and nuts.

**Step 5:** Make all electrical connections as marked on supplied terminal blocks.

**Step 6:** Slide EVSE housing down and secure with the #10–32 screws that were removed in Step 4.

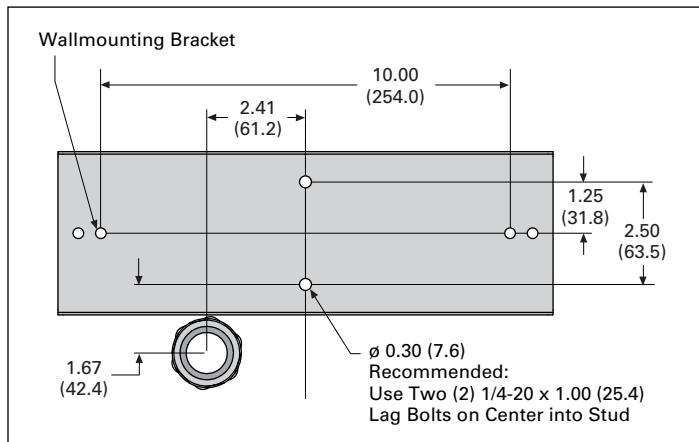

**Figure 15. Wallmount Bracket Layout—Back Wire and Bottom Conduit Entry**

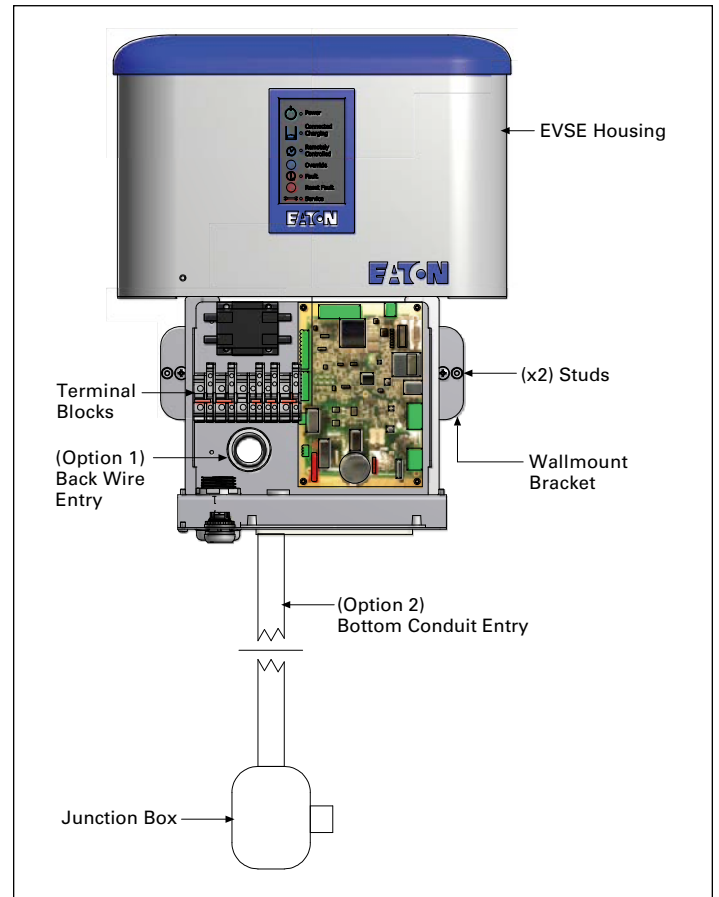

**Figure 16. EVSE Housing Removed from Internal Tray**

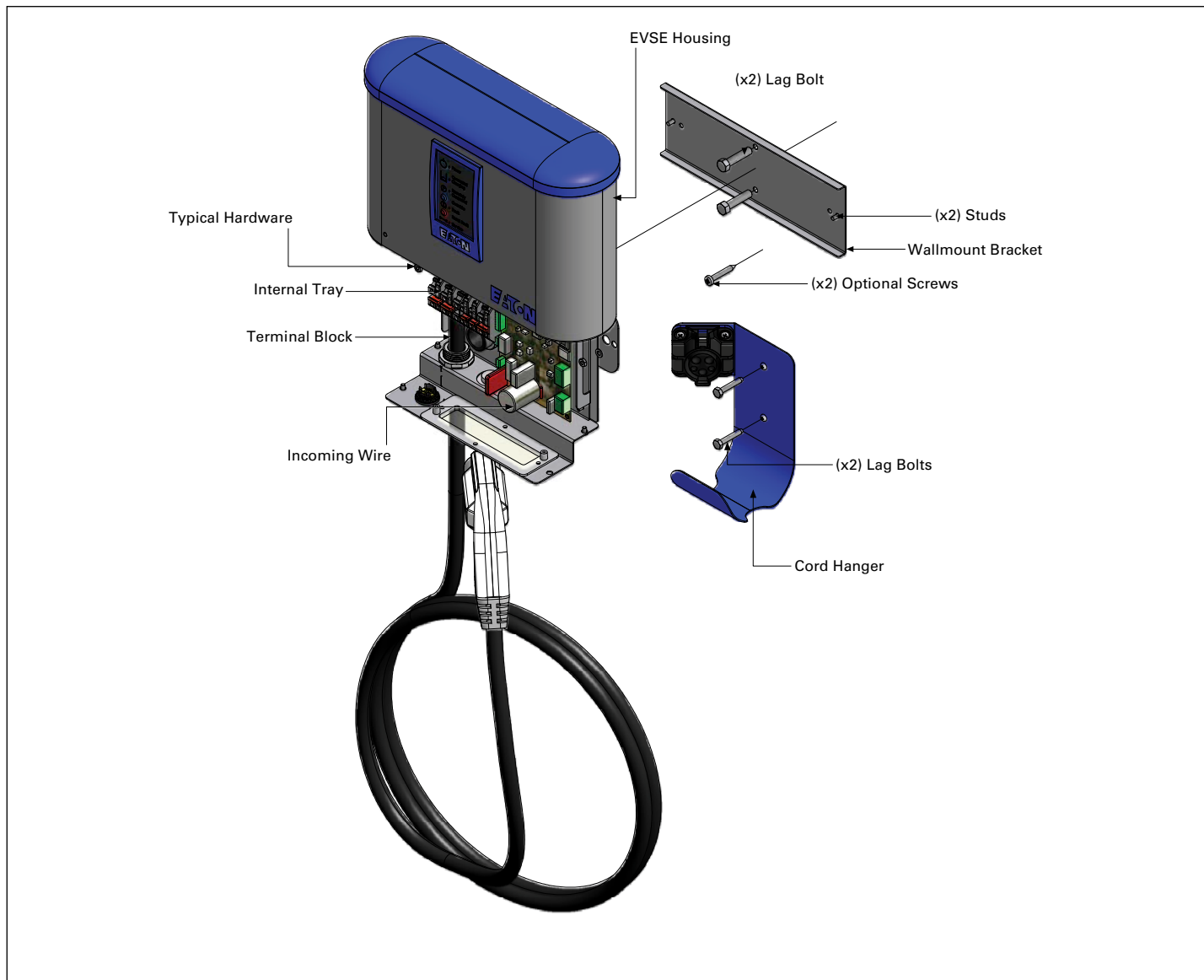

Figure 17. Hardwired Wallmount EVSE

### Pedestal installation

Once a proper site has been chosen and the electrical service has been run to the location, you can begin installation.

The EVSE pedestal ships from the factory pre-wired from the busbar to the EVSE(s).

**Step 1:** Using the mounting stud location diagram (pedestal base bolt pattern) in **Figure 18** as a guide, pour a concrete pad at least 24.00 inches wide x 16.00 inches deep x 10.00 inches thick with six 3/8–16.00-inch studs in locations as shown. The mounting studs shall be installed with 3/4-inch of thread above the finished concrete surface.

**Note:** Careful attention should be paid to the orientation of the stud locations. The vehicle side is noted on the drawing. Incoming and outgoing conduits shall be centrally located between the mounting studs.

**Step 2:** Remove the pedestal rear bus assembly cover from the EVSE pedestal assembly.

**Step 3:** Install the pedestal front cover onto the 3/8–16.00-inch studs as shown in the pedestal installation diagram in **Figure 19**, ensuring that feeder conductors are fed up through and out of the bus assembly opening. Insert a flat washer, a lock washer, and a nut onto each stud, and torque to 18 lb-ft.

**Step 4:** Make all electrical connections to the busbar assembly. Torque mechanical lugs to 8 lb-ft and compression-type terminal connections to 5 lb-ft.

**Step 5:** Replace the pedestal rear bus assembly cover and secure using four #8–32 screws.

**Step 6:** Install the hardware cover plates onto the base of the pedestal to cover the mounting studs. Secure the covers with two #8–32 screws each.

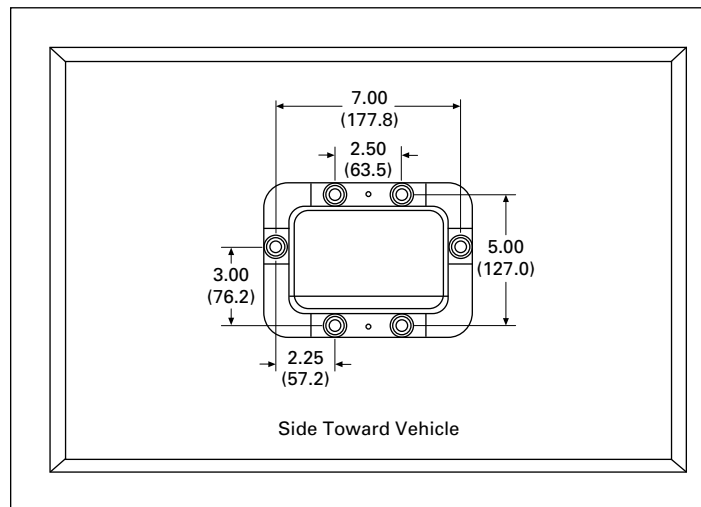

**Figure 18. Pedestal Base Bolt Pattern**

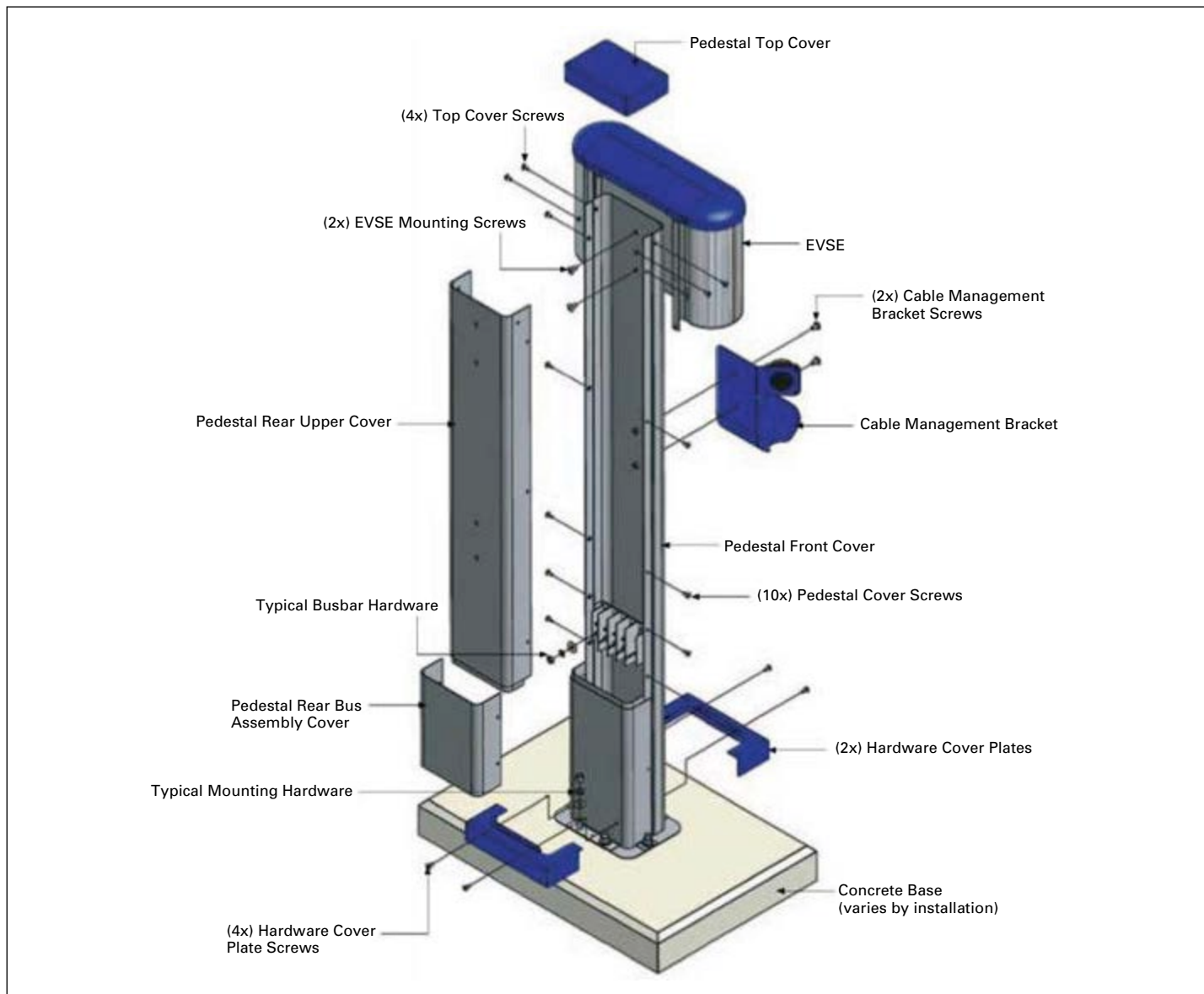

Figure 19. Single Pedestal Illustration

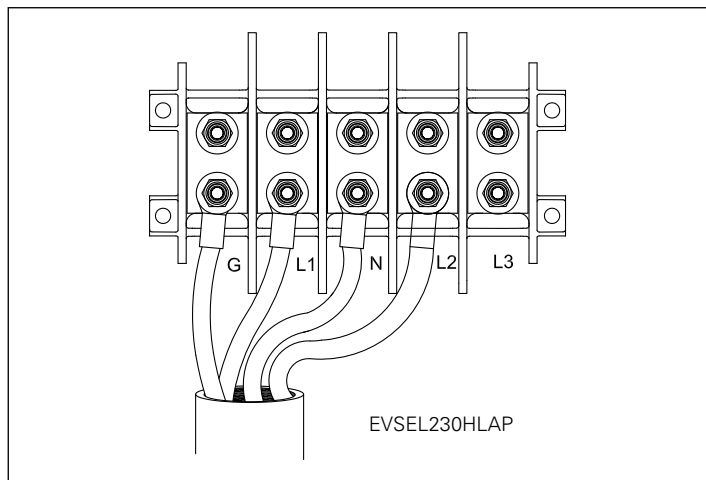

Figure 20. Level 2 Single Pedestal Terminal Block with Light

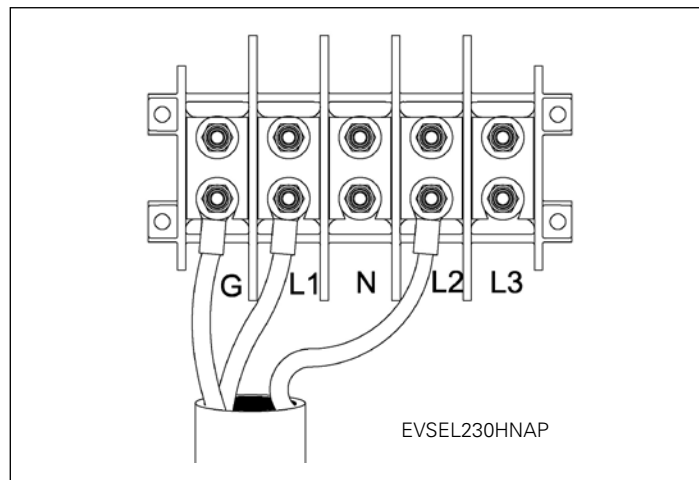

Figure 21. Level 2 Single Pedestal Terminal Block without Light

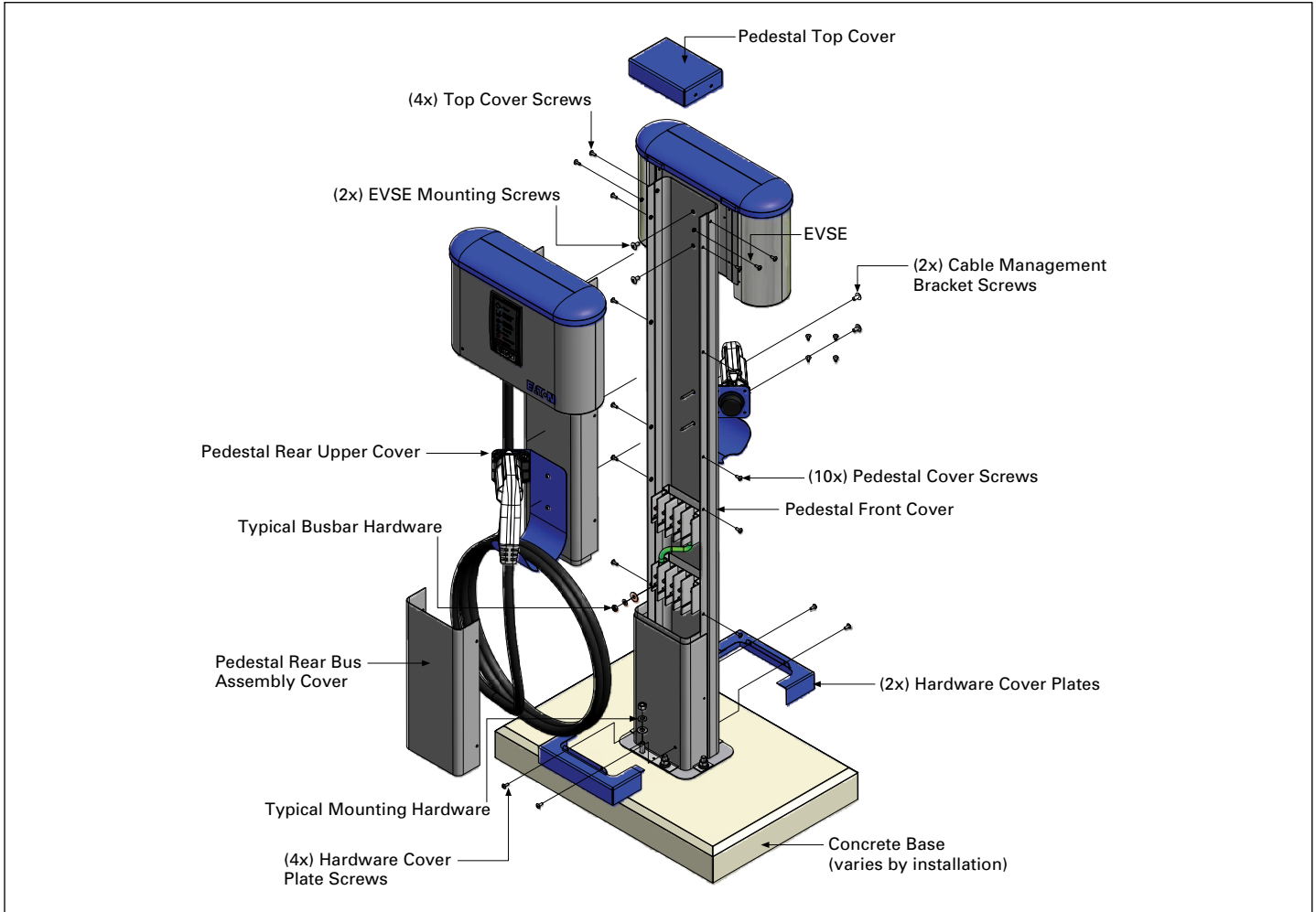

Figure 22. Dual Pedestal Illustration

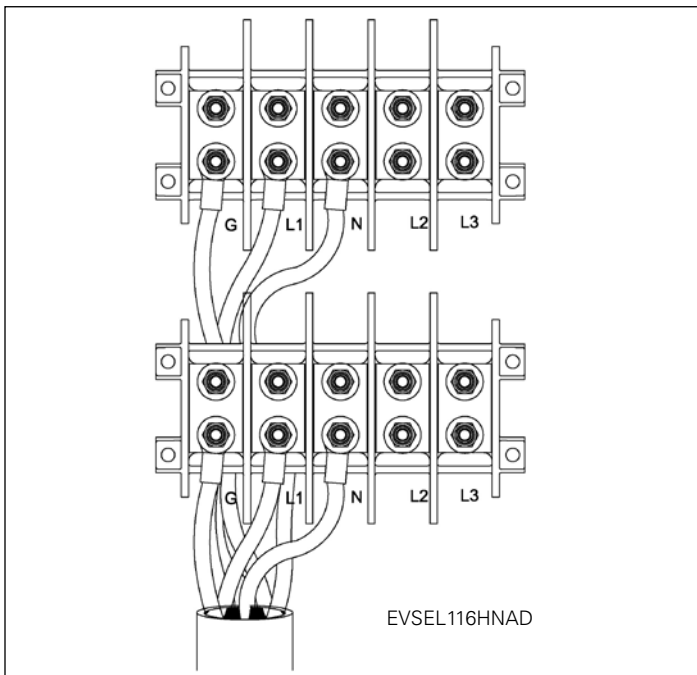

Figure 23. Level 1 Dual Pedestal Terminal Block

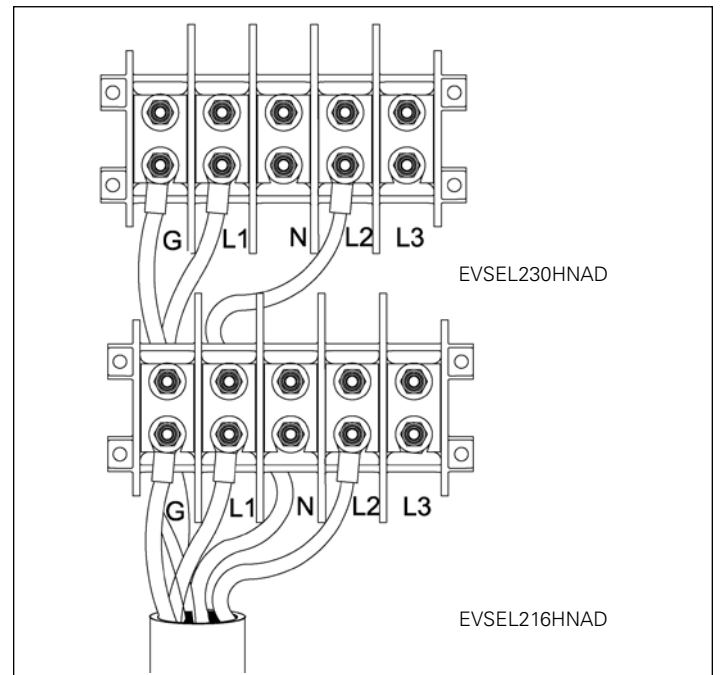

Figure 24. Level 2 Dual Pedestal Terminal Block without Light

## Termination and configuration

### WARNING ELECTRICAL

**LOCKOUT/TAGOUT ALL ELECTRICAL SOURCE CIRCUITS FEEDING THE UNIT(S) IN THE OPEN POSITION BEFORE BEGINNING WIRING OR TERMINATIONS. FAILURE TO FOLLOW THE INSTRUCTIONS COULD RESULT IN SEVERE BODILY INJURY OR DEATH. ONLY CERTIFIED PERSONNEL FAMILIAR WITH THE OPERATION AND CONSTRUCTION OF THIS EQUIPMENT SHOULD INSTALL, ADJUST, MODIFY, AND SERVICE THIS EQUIPMENT. FAILURE TO FOLLOW THE INSTRUCTIONS COULD RESULT IN SEVERE BODILY INJURY OR DEATH.**

#### Wire terminations

For a typical installation, the only field wire terminations will be the incoming electrical service wires.

#### Electrical service wires

Terminate the incoming electrical service wires to the charging station's provided terminal block, following the designations for each wire: L1 (Line 1), L2 (Line 2), N (Neutral), and G (Ground). Care must be taken when terminating incoming conductors to ensure proper phasing and grounding. If service light is present when testing EVSE, phase change of incoming conductors should correct the service light issue.

#### Grounding instructions



This product must be connected to a grounded, metal, permanent wiring system, or an equipment-grounding conductor must be run with the circuit conductors and connected to the equipment grounding terminal.

Once all terminations are made, close the unit's service door, confirm that the unit is securely mounted, and turn on the feeding circuit to the unit.

## Confirming installation and first use

### Boot-up and first use test

Table 4. Main Icon Descriptions

Icon	Icon Status	
	Blink	Steady
 Power	N/A	Unit ready for charge session
 Connected Charging	Vehicle connected, EVSE ready, waiting on vehicle	Vehicle charging
 Remotely Controlled	Rate of charge controlled remotely and charging set to INACTIVE	Rate if charge controlled remotely and charging set to ACTIVE

**Step 1:** Ensure that the electrical service wires are landed correctly, according to this manual. Make sure that the station access door is closed.

**Step 2:** Power ON the distribution breaker.

**Step 3:** During initial EVSE boot-up, the user interface will cycle all icons.

**Step 4:** After boot-up, the POWER icon will be STEADY per the above table. If this is not the case, please verify that all incoming service connections are landed appropriately and that the distribution breaker is intact. If the POWER icon still does not appear, please call technical support.

**Step 5:** If an SAE J1772-compliant electric vehicle is available, please connect the EV connector to the vehicle inlet. You may also use an Eaton vehicle simulator.

**Step 6:** The CHARGING indicator will begin to blink.

**Step 7:** Almost immediately, the vehicle will engage a charge session (the contactor will close, and power will be supplied to the vehicle).

**Step 8:** When power is being supplied to the vehicle, the CHARGING indicator will move from a BLINK status to STEADY status, signifying that current is flowing to the vehicle.

**Step 9:** You may now remove the connector from the vehicle at your leisure.

#### Ground fault test

The ground fault detection feature is self-tested every time the unit starts a plug session to charge a vehicle. A user can manually test the ground fault feature at any time by pressing and holding the Reset button (right button) for seven seconds.



If the test passed successfully, the Fault light will flash once. If it detects a problem, the POWER icon will turn off, and the Services light (wrench icon) will have a medium single blink until power is cycled to the unit. See the troubleshooting section on **page 18** for more details.

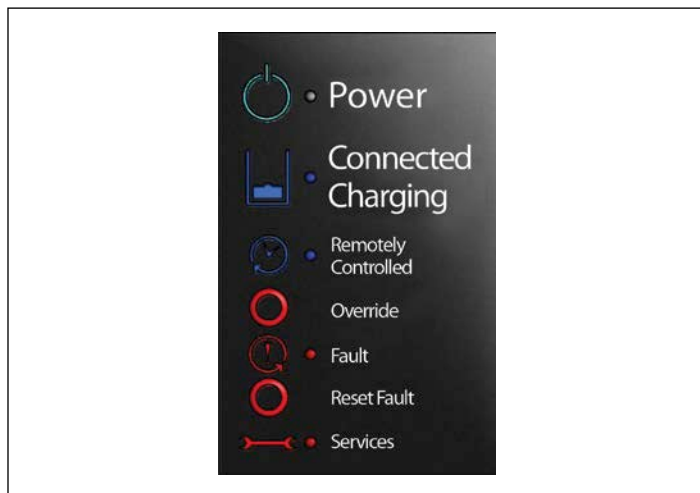

Figure 25. Full User Interface

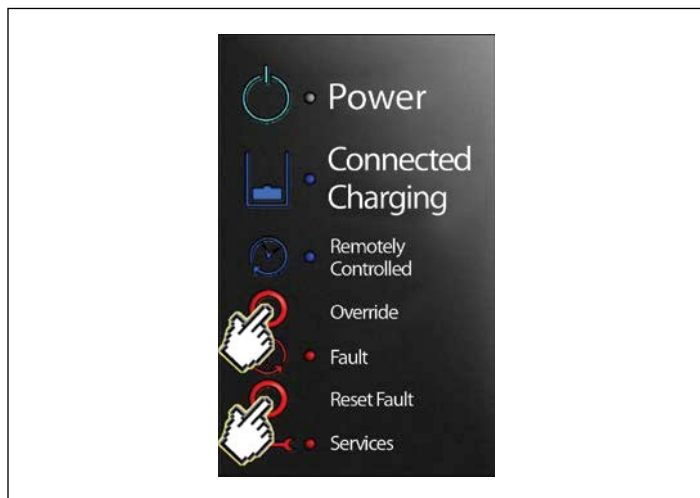

Figure 26. Ground Fault Reset

For ground fault reset, press and hold the Override button and the Reset Fault button until all operation lights flash on momentarily.

## Specifications

The Eaton residential EVSE charging station is compliant with the following standards:

- Society of Automotive Engineers (SAE) J1772 2010 EV Conductive Charge Coupler and Station
- NFPA® 70 National Electrical Code, Article 625, Electric Vehicle Charging System
- UL® 2231 Personnel Protection Systems for EV Charging Circuits
- UL 2594 EV Supply Equipment (Outline of Investigation)
- UL 1998 Software in Programmable Components
- FCC compliant, Part 15

Table 5. Electrical and Mechanical Specifications

Model Level	Eaton	
	L116 Level 1	L216 and L230 Level 2
<b>Electrical Input</b>		
Input power	1.9 kW	7.2 kW (L230 style) 3.8 kW (L216 style)
Input voltage	110/120 Vac	208/240 Vac
Input (amperage) current	16 A (L116 style)	30A (L230 style) 16A (L216 style)
Breaker size (non-GFCI) on dedicated circuit	20 A	20 A/40 A
<b>Electrical Output</b>		
Power output	1.9 kW	7.2 kW (L230 style) 3.8 kW (L216 style)
Output voltage	110/120 Vac	208/240 Vac
Output amperage	16A (L116 style)	30A (L230 style) 16A (L216 style)
Connector	SAE J1772	SAE J1772
Installation	Hardwire/cord-and-plug connected	Hardwire/cord-and-plug connected
Cable length (in feet)	24	24
Safety	ETL	ETL
Certifications	ETL listed to UL 2594/2231/1998 CETL listed	ETL listed to UL 2594/2231/1998 CETL listed
Interlocked power protection	Yes	Yes
Ground fault protection	20 mA (hardwired style) 5 mA (cord-and-plug connected style)	20 mA (hardwired style) 5 mA (cord-and-plug connected style)
Overcurrent protection	Yes	Yes
<b>Physical/Environmental Dimensions</b>		
Wallmount dimensions (in inches) H x W x D	10.00 x 15.00 x 5.00	10.00 x 15.00 x 5.00
Pedestal dimensions (in inches) H x W x D	55.00 x 15.00 x 9.00	55.00 x 15.00 x 9.00
Operating temperature	-30 °C to 50 °C	-30 °C to 50 °C
<b>Enclosure</b>		
Type rating	NEMA 3R	NEMA 3R
Enclosure material	Stainless steel	Stainless steel
Status indicator	5 LEDs: 2 bottoms	5 LEDs: 2 bottoms
Weight	23 lbs	23 lbs
Operating humidity	90% RH, noncondensing	90% RH, noncondensing
Automatic reset after nuisance trip feature	Yes	Yes
Randomized restart on power failure (delay before charging resumes after a power failure)	Yes	Yes
Mechanical operations	10,000 cycles (EV connector, replaceable) 100,000 cycles (contactor, replaceable)	10,000 cycles (EV connector, replaceable) 100,000 cycles (contactor, replaceable)
LED Light	Yes	Yes

**Table 6. Single and Dual Pedestal Information**

Description	Single	Dual
<b>Physical/Environmental</b>		
EVSE pedestal— H x W x D (in inches)	54.00 x 15.20 x 9.70	54.00 x 15.20 x 13.30
<b>Weight</b>		
EVSE-mount pedestal	42 lbs	65 lbs
<b>Enclosure</b>		
Rating/material	NEMA 3R/ stainless steel	NEMA 3R/ stainless steel



## Troubleshooting

Many of the potential issues that a user may experience are shown in **Table 7**. Match what is happening on the interface to the pictures and then follow the corresponding instructions in the Recommendation column.

### **⚠ WARNING ELECTRICAL**

**ONLY QUALIFIED PERSONNEL FAMILIAR WITH THE CONSTRUCTION AND OPERATION OF THIS EQUIPMENT AND THE HAZARDS INVOLVED SHOULD OPEN THE UNIT, WHETHER IT IS TO ADJUST AND/OR SERVICE EQUIPMENT. FAILURE TO USE A TRAINED SERVICE TECHNICIAN COULD RESULT IN BODILY INJURY OR DEATH.**

**Table 7. Troubleshooting Interface**

What is Happening?	Pattern	Cause	Recommendation
All indicator lights are off	N/A	No electricity to unit	Turn on circuit feeding the unit with the breaker or fuse in electrical panel
		Secondary overcurrent device has detected a problem and tripped	Service technician should inspect unit and reset internal overcurrent device
		User interface cable unplugged	Service technician should plug in user interface
		Control board damage from overcurrent or surge	Call service technician
Only wrench indicator is lit	Slow ① single blink ②	Lockout error—the same temporary fault has occurred three consecutive times or a more serious fault was detected	Cycle power to the unit by turning off/on the breaker or fuse. Inspect the unit for damage to the cable, connector
	Medium ③ single blink ②	Ground fault detection failed self-test	Cycle power to the unit, but if continues, call a service technician
	Steady on 	Permanent error—installation wiring. Internal contactor or control board has failed	Call a service technician. Confirm 120 V between L1 and N. Replace contactor or control board
Exclamation point <b>and</b> charging	Exclamation point—slow ① single flash ④ and charge—slow ① single flash ④	Detected an overcurrent, currently not charging	Press Reset button (to right) —or— Wait for unit to automatically reset ⑤
	Exclamation point—fast ⑥ double flash ④ and charge—slow ① single flash ④	Pilot signal error from a dirty connector or damaged cable or from a dirty vehicle inlet	Unplug and try again. If continues, call a service technician to clean or replace cable/connector and/or bring the vehicle in for service.
	Exclamation point—steady ON and blue charge—slow ① single flash ④	Detected a ground fault, currently not charging	Press Reset button (to right) —or— Wait for unit to automatically reset ⑤
Wrench <b>and</b> charging is blinking	Service wrench—slow ① single flash ④ and blue charge—slow ① single flash ④	Vehicle's pilot signal has a diode malfunction	Unplug and try again. If continues, bring the vehicle in for service.

① "Slow" equals a duration of about 1.5 seconds.

② A Blink indicates that the light is instantly ON then OFF.

③ "Medium" equals a duration of about 1/4 of a second.

④ A Flash indicates that the light fades to ON and fades to OFF.

⑤ Automatic Reset feature must be enabled during installation—see the installation leaflet.

⑥ "Fast" equals a duration of about 1/8 of a second.

## Service manual

### Opening unit

---

#### **⚠ WARNING ELECTRICAL**

---

**ONLY QUALIFIED PERSONNEL FAMILIAR WITH THE CONSTRUCTION AND OPERATION OF THIS EQUIPMENT AND THE HAZARDS INVOLVED SHOULD OPEN THE UNIT, WHETHER IT IS TO ADJUST AND/OR SERVICE EQUIPMENT. FAILURE TO USE A TRAINED SERVICE TECHNICIAN COULD RESULT IN BODILY INJURY OR DEATH.**

---

To open the unit, use a snake-eye screwdriver to remove the four tamper-resistant screws at bottom of unit on either side of light lens. One Phillips head screw will need to be removed at bottom right corner of unit. This will allow you to slide the shell off of the wall bracket.

For more information,  
visit [www.eaton.com/plugin](http://www.eaton.com/plugin),  
call 1-855-ETN-EVSE (1-855-386-3873),  
or call your local Eaton sales office.

**Eaton**  
1000 Eaton Boulevard  
Cleveland, OH 44122  
United States  
[Eaton.com](http://Eaton.com)

© 2014 Eaton  
All Rights Reserved  
Printed in USA  
Publication No. IM00401002E / Z15714  
October 2014