

CHROMAPATH™ Aluminum Channels

Trimming Bars to a custom size:

Channels may be cut to size with an appropriately rated blade for metal cutting. Wet sand the cut channel edge with wet 400 grit sandpaper. For a smoother finish, follow-up with 600 grit, then 800 grit, 1200 grit, and finally 2000 grit for a flawless finish.

Trimming Lenses to a custom size:

Lenses can be trimmed to size with heavy duty scissors.

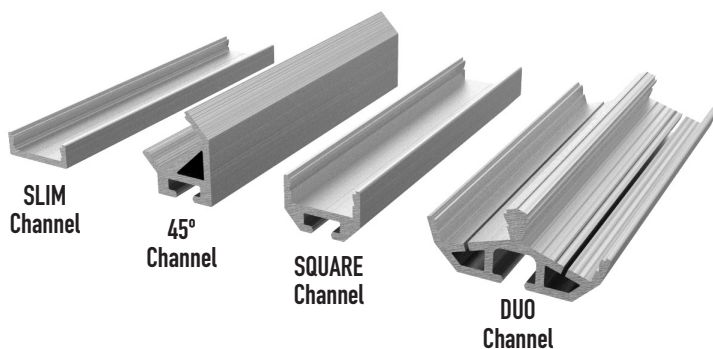

STRIP LIGHT & CHANNEL INSTALLATION

STEP 1: Preparing Strip Light

Trim strip light to desired length and attach connectors. Remove protective back from strip light (Fig. A).

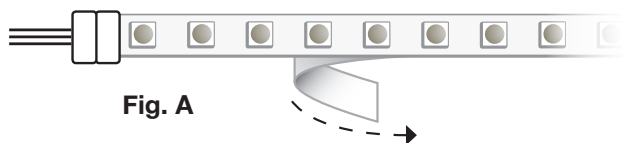

STEP 2: Mounting Strip Light

With adhesive surface exposed, apply strip to the trench of the aluminum channel (Fig. B) and move on to assembly.

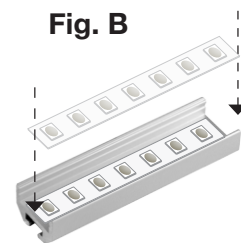

STEP 3: Assembly (End Caps are not for use with CLICKTIGHT™ DC Plug Connector)

1. Feed lead wires* through open end-cap.
2. Affix end-caps to channel.
3. Snap lens into place.
4. Align mounting clips and screw into place. Firmly press the channel onto mounting clips.

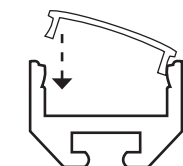
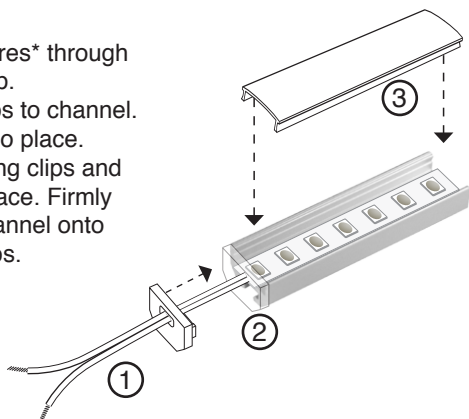

Lens Application

Mounting clips are not for use with SLIM channel.

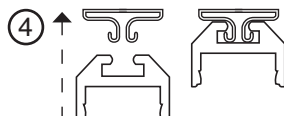

*Mounting Clips add 2.1mm to the channel height.

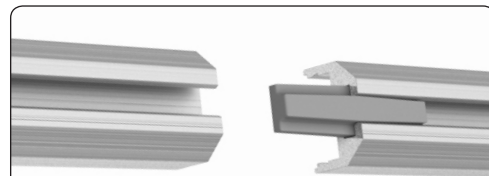

End-To-End Connection

The end-to-end connector plug is useful for seamless connections between two linear channels.

Not for SLIM channel

*This wire-lead opening is only large enough for no larger than 18/2 AWG lead-wires. For thicker wires, drill a larger opening in the end-cap.

STEP 4

Consult the diagrams below for the correct mounting orientation of your channel. For the SLIM Channel, use 3M Adhesive Tape (DI-0775) to mount the low profile channel into place.

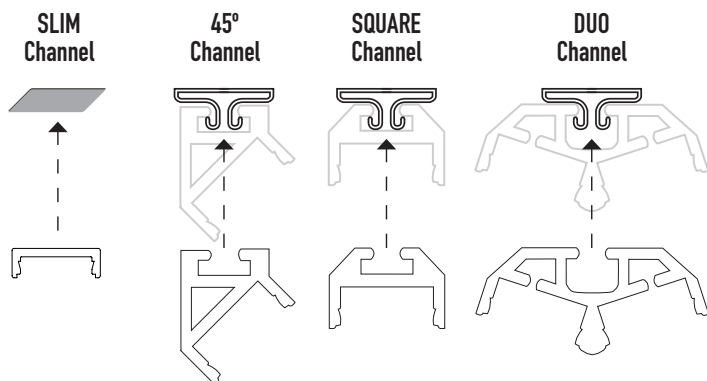

REMOVAL

CHROMAPATH™ Aluminum Channel can be removed with a flat-head screwdriver. Follow the diagram below to twist the channels free from their mounting clips.

Removal Tip: Put masking tape on screwdriver tip to prevent scratching the channels.

