

EV LED explosionproof LED luminaires

Cl. I, Div. 1, Groups C, D
 Cl. I, Zones 1 & 2, Group IIB
 Cl. II, Groups E, F, G
 Cl. III & Simultaneous Presence

UL Listed
 cUL Listed (certified by UL to CSA standards)
 Marine & Wet Locations
 Type 4X; IP66

2L

2L

EV LED luminaires are designed to provide durable and energy-efficient lighting in a variety of applications. Incandescent and HID general illumination models are available, along with a wildlife-friendly model and optional DC input voltage.

Model	Equivalent luminaire	Typical energy savings
201	100W-200W incandescent	Up to 85%
701	70W-100W HID	

Applications:

- Two lumen outputs for replacement of existing HID and incandescent luminaires
- Locations requiring continuous and consistent light levels in extreme ambient temperatures
- Areas requiring frequent on-and-off of lights
- Where flammable vapors, gases, ignitable dusts, fibers or flyings are present; indoors or outdoors
- Where extremely corrosive, wet, dusty, hot and/or cold conditions exist
- Type 4X, marine, wet locations and hose down environments
- Manufacturing plants, heavy industrial, chemical, petrochemical or pharmaceutical facilities, platforms, loading docks, tunnels, outdoor wall and stanchion mounted general area lighting

Certifications and compliances:

NEC/CEC:

- Class I, Division 1, Groups C, D
- T6 temperature rating at 55°C
- Class I, Zones 1 & 2, Group IIB
- Class II, Groups E, F, G
- Marine and wet locations, Type 4X, IP66
- UL Listed
- cUL Listed (certified by UL to CSA standards)

NEC:

- Class III, Simultaneous Presence

UL standards:

- UL844 – Electric Fixture Hangers for Hazardous Locations
- UL1598 – Luminaire
- UL1598A – Luminaire for Installation on Marine Vessels

CSA standard:

- C22.2 No. 137

Features:

- Instant illumination and re-strike
- Better visibility with crisp, white light
- T6 temperature rating – safely operate in the most hazardous environments
- Cold temperature operation/no warm-up required
- Easy installation – compact modular fixture attaches onto existing Champ® mounting module
- Energy-efficient – up to 85% reduction in energy used
- Provides up to 50,000 hours rated life – eliminates need for frequent lamp replacement
- Contains no mercury or other hazardous substances
- Shock- and vibration-resistant solid-state luminaires have no filaments or glass components that could break – greatly reduces the risk of premature failure
- Operating ambient: -30°C to 55°C (AC), -30°C to 40°C (DC)

Standard materials:

- Body, mounting modules and guard – copper-free aluminum with Corro-free epoxy powder coat
- Globe – heat and impact-resistant glass
- Gaskets – silicone
- External hardware – stainless steel

LED system:

- High brightness light emitting diode (LED) arrays
- Color temperature: 3000K (CRI 82) and 5600K (CRI 65) options available
- Amber color available for wildlife-friendly applications
- Advanced heat sink design ensures LED does not exceed manufacturer's temperature ratings across all specified ambient conditions
- LM-79 and LM-80 reports available

Electrical ratings:

	C201	C701	A201	C201/DC
Voltage range	100-277 VAC	100-277 VAC	100-277 VAC	12-24 VDC
Frequency	50/60 Hz	50/60 Hz	50/60 Hz	
Input power	15W	30W	36W	15W
Input amps (max.)	0.12A	0.25A	0.36A	1.15A
Power factor	0.86	0.87	0.98	0.88



Photometrics:

- Complete photometrics can be found at www.crouse-hinds.com/photometrics

EV LED explosionproof LED luminaires

Cl. I, Div. 1, Groups C, D
 Cl. I, Zones 1 & 2, Group IIB
 Cl. II, Groups E, F, G
 Cl. III & Simultaneous Presence

UL Listed
 cUL Listed (certified by
 UL to CSA standards)
 Marine & Wet Locations
 Type 4X; IP66

2L

2L

Ordering information:

Mounting style	Cool color temperature		Warm color temperature		Wildlife-friendly
	C201	C701	W201	W701	A201
Luminaire only	EVLEDC201	EVLEDC701	EVLEDW201	EVLEDW701	EVLEDA201
3/4" pendant	EVLEDA2C201	EVLEDA2C701	EVLEDA2W201	EVLEDA2W701	EVLEDA2A201
1" pendant	EVLEDA3C201	EVLEDA3C701	EVLEDA3W201	EVLEDA3W701	EVLEDA3A201
3/4" ceiling mount through feed	EVLEDCX2C201	EVLEDCX2C701	EVLEDCX2W201	EVLEDCX2W701	EVLEDCX2A201
1" ceiling mount through feed	EVLEDCX3C201	EVLEDCX3C701	EVLEDCX3W201	EVLEDCX3W701	EVLEDCX3A201
3/4" wall mount through feed	EVLEDBX2C201	EVLEDBX2C701	EVLEDBX2W201	EVLEDBX2W701	EVLEDBX2A201
1" wall mount through feed	EVLEDBX3C201	EVLEDBX3C701	EVLEDBX3W201	EVLEDBX3W701	EVLEDBX3A201
3/4" bulkhead mount	EVLEDBH2C201	EVLEDBH2C701	EVLEDBH2W201	EVLEDBH2W701	EVLEDBH2A201
1 1/4" stanchion mount	EVLEDJ4C201	EVLEDJ4C701	EVLEDJ4W201	EVLEDJ4W701	EVLEDJ4A201

Note: To order a fixture without a guard, remove '1' from the end of the catalog number. (Example: EVLEDAC20 for 3/4" pendant, no guard).
 To order a fixture with 10-30 VDC input voltage (available on 20 series only), add '/DC' to the end of the catalog number. (Example: EVLEDAC201/DC).
 To order a fixture with colored inserts (available on C20 series only), add a 'G' (for green) or 'R' (for red) to the end of the catalog number. (Example: EVLEDAC201G).

Family tree:

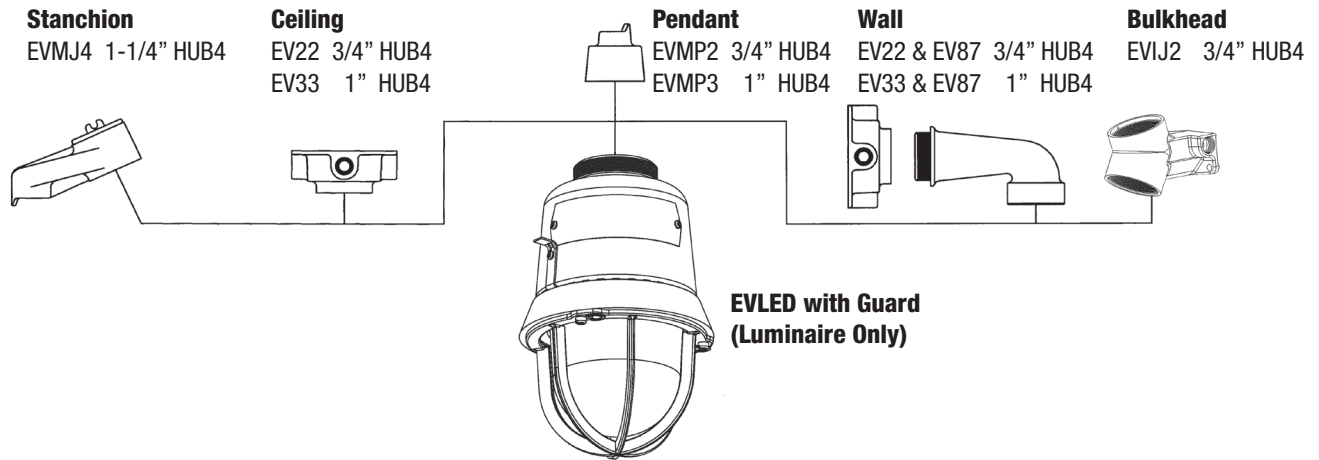

EV LED explosionproof LED luminaires

Cl. I, Div. 1, Groups C, D
Cl. I, Zones 1 & 2, Group IIB
Cl. II, Groups E, F, G
Cl. III & Simultaneous Presence

UL Listed
cUL Listed (certified by
UL to CSA standards)
Marine & Wet Locations
Type 4X; IP66

2L

Dimensions (in inches):

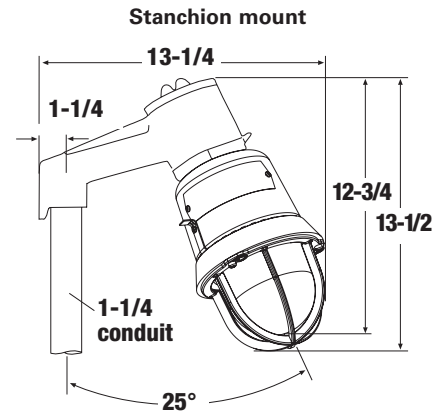
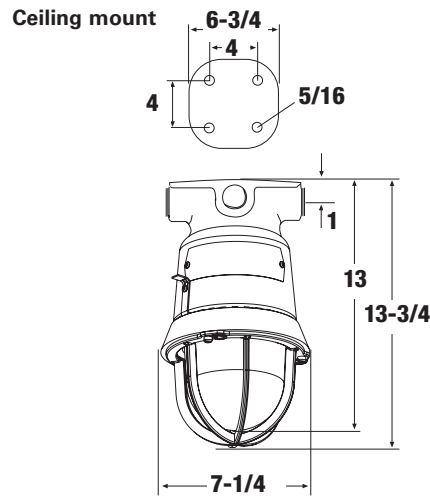
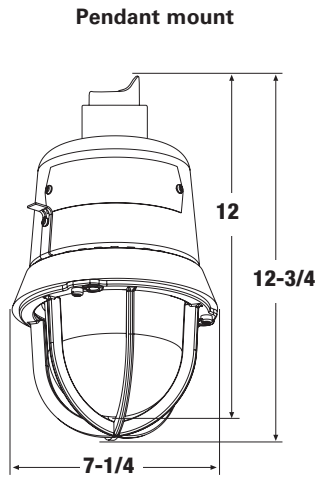

Wall mount

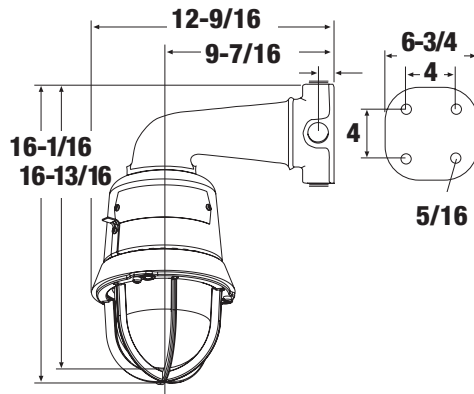

Bulkhead

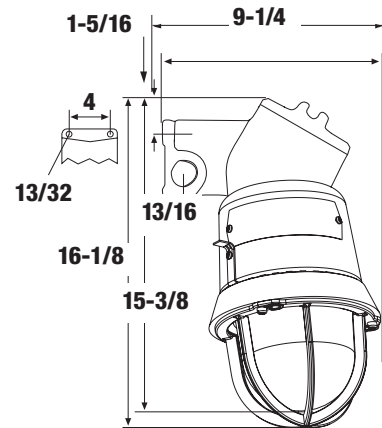

Net luminaire weights:

	Weight (lbs.)
EV LED with guard	11.0
Add mounting modules:	
Pendant	1.0
Ceiling	2.0
Wall	4.5
Bulkhead	2.2
Stanchion	2.5