



Greengate

Dual Technology Ceiling Mounted Low Voltage Occupancy Sensor



RoHS

- Model # OAC-DT-0501
- Model # OAC-DT-0501-R
- Model # OAC-DT-1000
- Model # OAC-DT-1000-R
- Model # OAC-DT-2000
- Model # OAC-DT-2000-R

General Information

- Read all instructions on both sides of this sheet first
- Install in accordance with ALL local codes
- For indoor use only
- For Use with Greengate Switchpacks & Systems Only
- Do not run any Greengate Low Voltage Wiring in the same conduit as power conductors

Specifications

Power Requirements:

- Input:
- 10-30 VDC from Greengate Switchpack or Greengate system. Maximum current needed is 25mA per sensor

Output:

- Open collector output to switch up to ten Greengate Switchpacks.
- BAS with Isolated Form C Relay (-R model)
- Isolated Form C Relay Ratings: 1A 30 VDC/VAC

Operating Environment:

- Temperature: 32° F – 104° F (0° C – 40° C)
- Relative Humidity: up to 90% non-condensing

Description

The OAC-DT Ceiling Mount Low Voltage Occupancy Sensor is a Passive Infrared (PIR) and Ultrasonic (US) motion sensing lighting control, used for energy savings and convenience. PIR is used to turn the lights ON and then either technology is used to keep the lights ON. When motion is detected, the blue wire is electronically connected to the red wire, energizing the relay in the switchpack to turn on the load. If vacancy is detected, the blue wire is disconnected from the red, causing the relay to open turning OFF the load. The red lead is 10-30 VDC supply, the black lead is common, and the blue is the relay control.

The sensor includes self-adaptive technology that continually adjusts to conditions by adjusting sensitivity and Time Delay in real-time.

Coverage

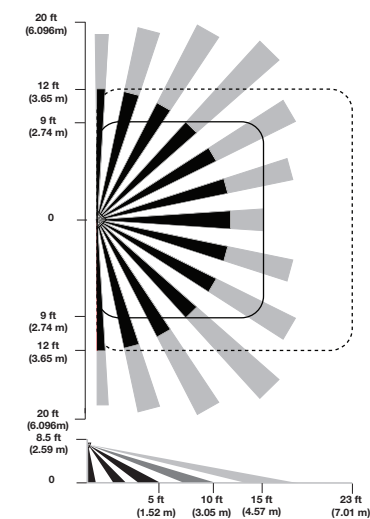

OAC-DT-0501-R Coverage Diagram

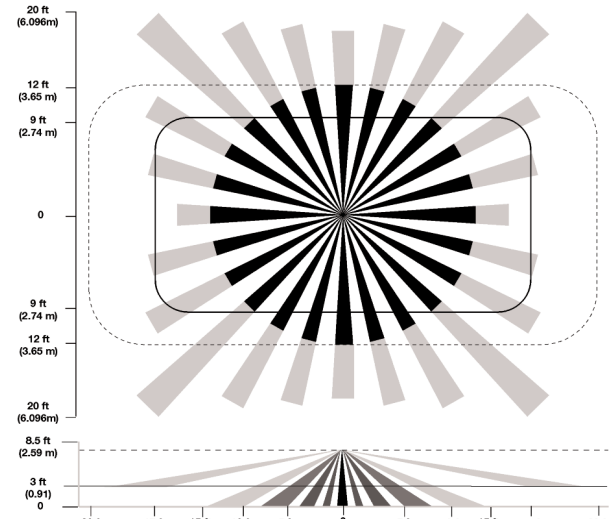

OAC-DT-1000-R Coverage Diagram

Coverage

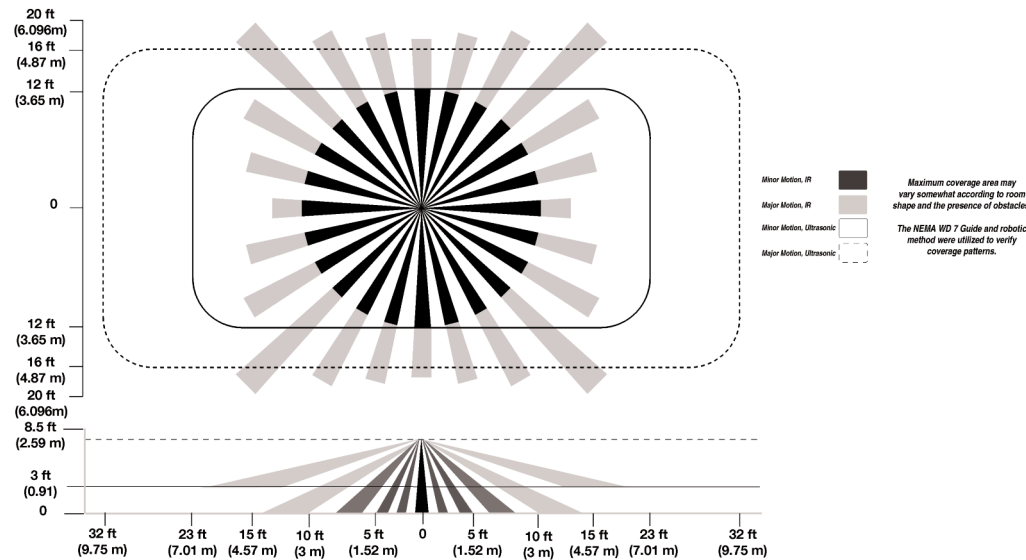

OAC-DT-2000-R Coverage Diagram

Location

The maximum coverage area may vary somewhat according to room shape and the presence of obstacles. Decrease total coverage area by 15% for "soft" rooms (for example, heavy draperies or heavy carpeting). The sensor must have a clear view of the area to be controlled. The sensor will not "see" through glass. Mounting height should not exceed 12 feet. Optimum mounting height is 8 to 10 feet. Mount the sensor so the grilles face the open portion of the room and are not facing a nearby wall, door, window, or other obstructing object. Avoid pointing into hallways. Mounting at fixture height is most effective. *To prevent false activation, the sensor should be mounted away from the air supply duct a minimum of 4 to 6 feet.

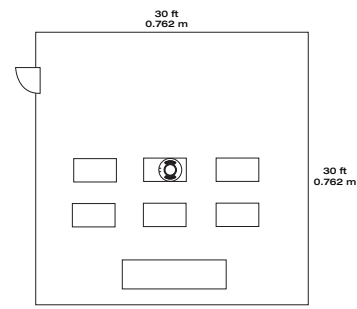

OAC-DT-1000 & OAC-DT-2000

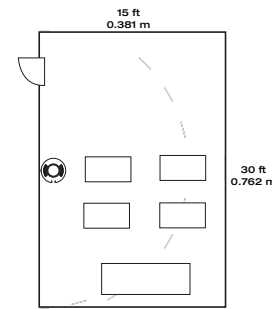

OAC-DT-0501

Installation

The OAC-DT sensor can be mounted to the ceiling, junction box, or round fixture with raceway.

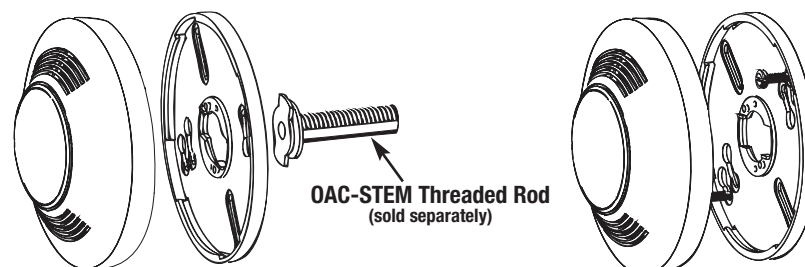

Wiring

CAUTION: Before installing or performing any service on a Greengate system, the power **MUST** be turned OFF at the branch circuit breaker. According to NEC 240-83(d), if the branch circuit breaker is used as the main switch for a fluorescent lighting circuit, the circuit breaker should be marked "SWD". All installations should be in compliance with the National Electric Code and all state and local codes.

NOTE REGARDING COMPACT FLUORESCENT LAMPS: The life of some compact fluorescent lamps (CFLs) is shortened by frequent automatic or manual switching. Check with CFL and ballast manufacturer to determine the effects of cycling.

1. Make sure power is turned OFF at the branch circuit breaker.
2. Wire units as shown in wiring diagrams per applicable voltage requirements. (Use twist-on wire connectors for all connections) CAP ALL UNUSED WIRE LEADS.
3. Mount unit to ceiling, junction box, or round fixture with raceway.
4. Turn power back ON at the branch circuit breaker and wait 2 minutes for the unit to stabilize.
5. Make necessary adjustments. (See Checkout and Adjustments section)

One Sensor, One Switchpack

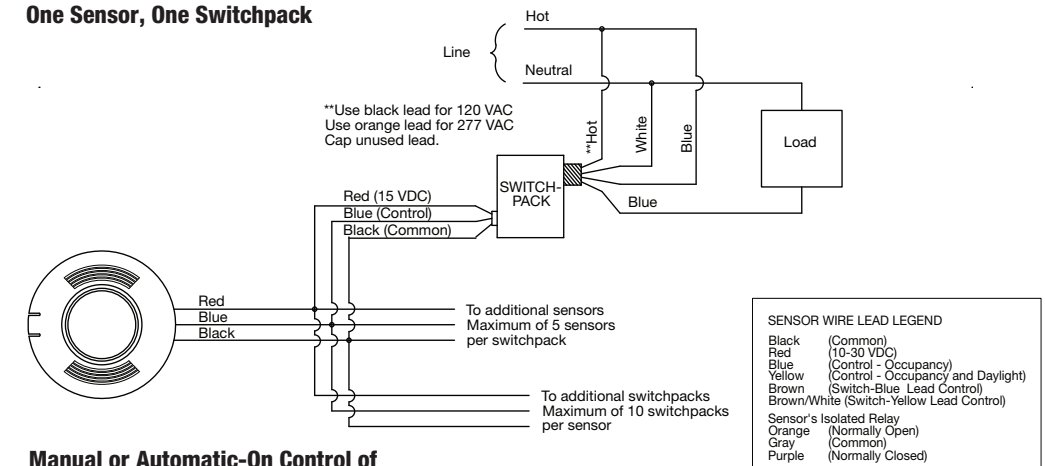

Manual or Automatic-On Control of Two Standard Switchpacks

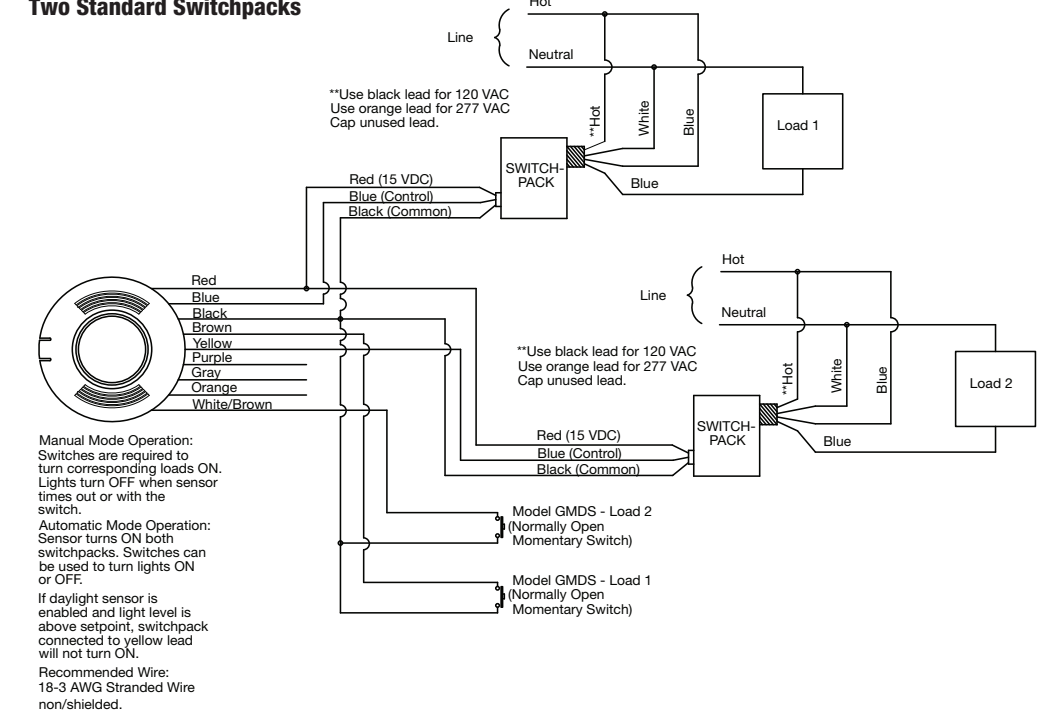

DIP Switch Settings

DIP Switch Legend

DIP Switch	Time Delay		Activation		PIR Sensitivity	Walk-Through Mode	LEDs	Override	Sweep	Full/Half Logic	HVAC/Tracking	Zero Time Delay
	1	2	Relay 1	Relay 2								
Auto*	▼	▼	Auto	Auto	Full	Disable	Enable	Disable	Disable	Full	Disable	Disable
5 Minutes	▼	▲	Manual	Manual	50%	Enable	Disable	Enable	Enable	Half	Enable	Enable
15 Minutes	▲	▼	(-R model only) (-R model only)						(-R model only)		(-R model only)	
30 Minutes	▲	▲										

Default =

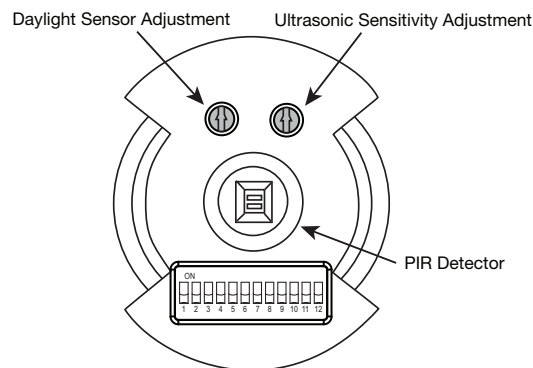

Checkout and Adjustment

LED Indicators Functionality

	During Installer/Test Mode	While in User Mode
LED Flashing Speed	LEDs will flash once per ¼ second	LEDs will flash once per second
Duration	10 minutes	10 to 30 minutes

Adjustments should be made with the HVAC system ON. Use only insulated tools to make adjustments.

Self-Adjust

Sensor is shipped in the Self-Adjust Mode. This applies to Time Delay, US, and PIR sensitivity. In preparation for the Installer Test, the time delay is set to 15 seconds, after the sensor is installed, powered-ON and has stabilized, the unit will Time-out 15 seconds after the last motion detected. Coverage and sensitivity can be confirmed by watching the Green (US) and Red (PIR) indicator LEDs on the front of the sensor, while moving around the room.

- Walk around the room and monitor LEDs. LEDs should only turn ON for ¼ second with each motion. (If LEDs do not turn ON, go to Installer Adjustments - Sensitivity Adjustments Section)
- Stand still six to eight feet away from the sensor for five seconds. LEDs should not turn ON. (If any LED turns ON, note LED and go to Installer Adjustments – Sensitivity Adjustment section)
- Walk outside the room and wait 15 seconds for the lights to turn OFF. (If lights do not turn OFF go to Installer Adjustments Section)
- Re-enter the room to activate sensor. (If lights do not turn ON go to Troubleshooting Section)
- The unit will remain in Test Mode for 10 minutes then automatically exit Test Mode and go for 10 min. Time Delay User Mode setting.

Note: To place into Test Mode, toggle DIP Switch 10 out of its current position, wait 3 seconds, and then back in to its original position. To force into 10 min User Mode move Dip Switches 1 and 2 down. (If DIP Switches 1 and 2 are already down, toggle DIP Switch 1 out of its current position, wait 3 seconds, and then back to its original position) While in Test Mode, the LEDs will flash once per 1/4 second.

Installer Adjustments

Sensitivity Adjustments

Ultrasonic Sensitivity (Green LED) – Using a small flathead screw driver turn the green potentiometer so that the arrow points up.

- Stand in different areas of the room and wave your hands.
- If the Green LED does not turn ON, increase the US sensitivity by turning the green potentiometer clockwise in small increments. Repeat Step 1.
- Stand still six to eight feet away from sensor for five seconds. LED should not turn ON.
- If Green LED turns ON without motion or is constantly ON decrease the US sensitivity by turning the green potentiometer counter-clock-wise in small decrements. Repeat Step 3.

PIR Sensitivity

- Stand in different areas of the room and wave your hands.
- If the Red LED does not turn ON, check for any obstructions.
- Stand still six to eight feet away from sensor for five seconds. LED should not turn ON.
- If Red LED turns ON without motion or is constantly ON adjust PIR sensitivity to 50% by moving DIP Switch 5 up.

Field-of-view outside the space

- Adjust PIR sensitivity to 50% by moving DIP Switch 5 up.
- Adjust Ultrasonic Sensitivity.

Daylight Adjustments (-R Model Only 0 to 300 foot-candles)

If this feature is not needed, leave the light level at maximum (fully clockwise).

The Daylighting feature prevents the lights from turning ON when the room is adequately illuminated by natural light. If there is enough light in the room regardless of occupancy, the sensor will hold the lights OFF. If there is not enough light in the room, the sensor will allow the lights to turn ON when occupied.

Full and Half Logic Modes (See DIP Switch legend):

In both Full and Half Logic modes, lights connected to the yellow control lead will not turn ON upon occupancy activation, should the ambient light level exceed the preset foot-candle level.

After activation:

Full Logic Mode - should the ambient light level exceed the preset foot-candle level, the lights connected to the yellow control lead will turn OFF. The lights will remain OFF, until the ambient light level falls below the set point.

Half Logic Mode – the output state of the yellow control lead will not change with ambient light changes, after occupancy activation. If the amount of natural light available rises above the setpoint, the daylight sensor will not turn the lights OFF while occupancy is being detected.

Note: Set the light level when the ambient light is at the level where no artificial light is needed. In order for this feature to function, the yellow control lead must be wired.

- With the load ON, put the sensor into Test Mode. To place into Test Mode, toggle DIP Switch 10 out of its current position, wait 3 seconds and then back in to its original position.
- Set DIP Switch 10 to Full or Half Logic Mode.
- Set the Light level to Minimum (fully CCW).
- Leave the room and let the sensor Time-out so lights are OFF. Enter the space and lights should remain OFF.
- Make sure not to block the sensor from the daylight source and adjust the light level potentiometer CW in small increments until the lights are ON. (Pause 5 seconds between each adjustment)
- Once the lights are ON, the load connected to the sensor will not turn ON if light levels are above the current illumination.

Time Delay Adjustments

People who remain very still for long periods of time may need a longer Time Delay than the default setting of 10 minutes. As long as Auto is enabled, the sensor will respond to each pair of False-offs with no normal OFF in between, by alternately making slight adjustments to either Time Delay (by 2 minute increments) or sensitivity, so there should be no need for manual adjustment. If manual adjustment is desired, refer to Time Delay settings in DIP Switch legend.

Reset sensor Time Delay to factory settings by moving DIP Switches 1 and 2 down. (If DIP Switches 1 and 2 are already down, toggle DIP Switch 10 out of its current position, wait 3 seconds, and then back to its original position)

Automatic Mode

In Automatic-ON Mode, the lights turn ON when a person enters the room. If optional momentary low voltage switches are used along with Automatic-ON Mode, activating the switch(es) while the load is ON turns the load OFF. When the load is turned OFF manually, as long as the sensor continues to detect occupancy the loads stay OFF. After the Time Delay expires, the lights stay OFF and the sensor goes back to Automatic-ON Mode. For wiring information for the optional momentary low voltage switch(es), please see the wiring section of the installation instructions.

Manual Mode (-R Model Only)

In Manual-ON Mode, the optional momentary low voltage switch(es) is required to turn the load(s) ON. Once activated the sensor will maintain the lights ON until motion ceases and the Time Delay expires. While the room is occupied the BAS relay remains active. After the Time Delay expires, the load(s) will automatically be turned OFF and the switch(es) must be used to turn the load(s) ON unless there is motion detected within the 10 second re-trigger period.

Lighting Sweep Option

If selected, this DIP Switch option forces an initial 60 second delay upon “power up” to prevent false activation in buildings with computer control systems.

- Move DIP Switch 9 up. If not selected (Dip Switch 9 down), upon initial “power up” or restoration of power the sensor will force the lights ON no matter the state of occupancy.

HVAC/Tracking Mode (-R model only)

If selected, Tracking Mode allows the load connection to the Form C relay to follow the state of the sensor’s blue lead. HVAC Mode allows the load connected to the Form C relay to remain ON when the lights are turned OFF manually. Applications may include keeping the room at a desired temperature while giving a presentation and the lights are OFF.

Zero Time Delay Mode

In Zero Time Delay Mode, the output is actuated for one second to signal another device that the space being monitored is occupied. Applications may include the use of a lighting control system to manage the delay of the lighting deactivation. Please see the wiring diagram section for wiring details.

When in Zero Time Delay Mode and Tracking Mode the load connected to the Form C relay shall follow the state of the sensor’s blue lead (zero Time Delay for the form C relay).

When in Zero Time Delay Mode and HVAC Mode, the load connected to the Form C relay remains ON for the standard Time Delay.

Override

The Override setting allows the lights to remain ON in the unlikely event of sensor failure.

- Move DIP Switch 8 up.
While in Override Mode, the optional low voltage momentary switch(es) will toggle the lighting load(s).

Troubleshooting

Issue	Possible Causes	Suggestions
Lights Will Not Turn ON automatically	Wall Switch OFF	Turn Wall Switch ON.
	If low voltage switch option is used, lights may have been turned-off manually.	Press low-voltage switch.
	Daylight Feature Enabled	If all lights are required to turn ON adjust DIP Switch 10 and/or daylight potentiometer
	Power interruption	Check incoming voltage and/or wiring
Lights Will Not Turn ON manually	Daylight Feature Enabled	If all lights are required adjust DIP switch 10 and/or daylight potentiometer.
	Power interruption	Check incoming voltage and/or wiring
If lights will still not turn ON, set sensor to override mode and call Technical Services at 1-800-553-3879		
Lights Will Not Turn OFF automatically	Override	Make sure sensor is not in Override Mode (DIP Switch 8 up).
	Ultrasonic Sensitivity set High	Lower sensitivity by turning green potentiometer CCW in small decrements.
	Sensor installed close to an air vent	Sensors should be installed minimum 4 - 6 feet away from any air vent and out of path of heavy airflow.
	Sensor installed close to indirect lighting.	Sensors should be mounted away from indirect lighting.
	Self-adjust	It may be possible for the unit to have self-adjusted the time delay to a 30 minute delay. If the lights do not turn OFF after 30 minutes follow next step.
	30 Minute Delay	Maximum time delay is 30 Minutes. Check DIP Switches to verify DIP Switch settings. If lights do not turn OFF at the set time delay, check next step.
	PIR activated by heat source other than occupant	Move DIP Switch 5 up.
Lights Will Not Turn OFF manually	Bypass	Check wiring to make sure sensor or switchpack are not bypassed.
	Override	Make sure sensor is not in Override Mode (DIP Switch 8 up).
If lights will still not turn OFF, call Technical Services at 1-800-553-3879		

Limited Warranty

All products manufactured by Cooper Controls and identified with the Greengate brand are warranted to be free from defects in material and workmanship and shall conform to and perform in accordance with Seller’s written specifications for a period of: Five (5) years from date of shipment for all occupancy sensors and Three (3) years from date of factory invoice for our hardware and software on Lighting Control Panels. We warranty all our standard relays for a period of 10 years from date of factory invoice. We guarantee the performance of our system to specifications or your money back. This warranty will be limited to the repair or replacement, at Seller’s discretion, of any such goods found to be defective, upon their authorized return to Seller. This limited warranty does not apply if the goods have been damaged by accident, abuse, misuse, modification or misapplication, by damage during shipment or by improper service. There are no warranties, which extend beyond the hereinabove-limited warranty, INCLUDING, BUT NOT LIMITED TO, THE IMPLIED WARRANTY OF MERCHANTABILITY AND THE IMPLIED WARRANTY OF FITNESS. No employee, agent, dealer, or other person is authorized to give any warranties on behalf of the Seller or to assume for the Seller any other liability in connection with any of its goods except in writing and signed by the Seller. The Seller makes no representation that the goods comply with any present or future federal, state or local regulation or ordinance. Compliance is the Buyer’s responsibility. The use of the Seller’s goods should be in accordance with the provision of the National Electrical Code, UL and/or other industry or military standards that are pertinent to the particular end use. Installation or use not in accordance with these codes and standards could be hazardous.

