

D2P and EWP Factory Sealed Circuit Breaker Panelboards

Explosionproof, Dust-Ignitionproof, Watertight, Corrosion-Resistant

NEC:

Class I, Division 1 and 2, Groups B♦, C♦, D

Class II, Division 1 and 2, Groups E, F, G

Class III

NEMA 3, 3R, 4, 4X, 5, 7BCD, 9EFG, 12

Applications

- Protection and control of electrical equipment and circuits such as lighting and heat tracing in hazardous locations or in damp, wet or corrosive conditions.
- D2P Series — designed for use in Class I, Division 2 areas where ignitable vapors or gases may be present under unusual conditions, or in Class II, Division 1 areas where combustible dusts are present.
- EWP Series — designed for use in Class I and Class II, Division 1 manufacturing and processing areas where ignitable vapors, gases or combustible dusts are present.
- Group B standard on all D2P and EWP panelboards.

Features

- Panel sizes:
 - “A” Board: up to 12 1-pole spaces
 - “B” Board: up to 24 1-pole spaces
 - “C” Board: up to 36 1-pole spaces
- 3” Main conduit openings for both top and bottom feed of junction compartment.
- Permits selection of 1-, 2- or 3-pole breakers. 10,000 Amp Vac interrupting capacity is standard. (22,000 AIC also available; contact your local representative.)
- Aluminum breaker actuators — spring loaded, corrosion resistant—feature self-locating design for actuating 1-, 2-, or 3-pole breakers in any sequence. Rotary actuating handles may be individually padlocked.
- Handles lock in either OFF or ON position without interfering with tripping of breakers.
- Double door — one for junction compartment and one for breaker compartment. Both doors are fully gasketed to provide raintight fit for both compartments.
- Two O-ring gaskets on each breaker handle shaft to prevent entrance of water or corrosion.
- Hinges allow the doors to be lifted off.
- Breakers prewired to terminal block minimizes installation time.
- Insulated neutral lug provided as standard.
- Panelboards use standard Cutler-Hammer QUICKLAG® + Industrial circuit breakers.
- Provision for drains/breathers in both compartments.
- Factory sealed — no external branch sealing fittings needed (except Division 1 Groups B and C ①).
- Voltage ratings: 120 Vac for 1-pole and up to 240 Vac for 2- or 3-pole.
- Type THHN minimum size #10 AWG copper wire — 90 °C (194 °F) — used in panelboards. Main lug feeder wires are crimped and installed in single conductor.
- Stainless steel captive, spring-out Quad-Lead® bolts for ease of access.

Standard Materials

- Housings: copperfree (4/10 of 1% max.) aluminum
- Hardware: stainless steel

Standard Finishes

- Housings: gray epoxy powder coat

♦ For Groups B and C, all conduits must be sealed adjacent to enclosure.

① Contact your local representative for more information.

+ Quicklag and Cutler-Hammer are registered trademarks of the Eaton Corporation.

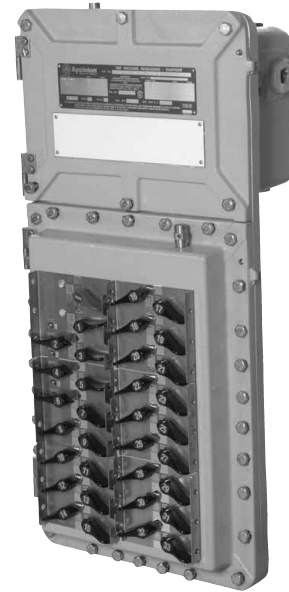

Options ①

Must be listed in alphanumeric sequence at the end of the catalog number.

- Panel Options
 - Drain and breather sets add suffix — **DV**.
 - Ground Terminal Bar add suffix — **GJ**.
 - Grounded neutral lug add suffix — **GNL**.
 - For bottom and side feed only (no conduit holes drilled in top) add suffix — **NTE**.
 - Factory installed wired provisions for future installation of circuit breakers in the field, on request. Consult contact your local representative for information.
 - For +50 °C (+122 °F) breaker rating, add suffix — **V**.
- Breaker Options
 - Equipment protection devices, 1-pole 40 Amp max. and 2-pole 50 Amp max. (1- or 2-Pole -30 mA sensitivity) add suffix — **EPD**.
 - Ground fault interrupter, 1-pole 40 Amp max. and 2-pole 50 Amp max. (1- or 2-Pole -5 mA sensitivity) circuit breakers add suffix — **GFI** (available on all circuit positions).
 - For auxiliary contacts, contact your local representative for information.
 - For breakers for use in HID lighting applications, add suffix — **HID**.
 - Factory installed main breaker, maximum 100 Amp. Add suffix — **MB** for main breaker. Main circuit breaker occupies branch breaker spaces.

NEC Certifications and Compliances

- UL Standard: UL 877, UL 1203
- UL Listed: E12108

D2P and EWP Factory Sealed Circuit Breaker Panelboards

Explosionproof, Dust-Ignitionproof, Watertight, Corrosion-Resistant

NEC:
Class I, Division 1 and 2, Groups B ♦, C ♦, D
Class II, Division 1 and 2, Groups E, F, G
Class III
NEMA 3, 3R, 4, 4X, 5, 7BCD, 9EFG, 12

DISTRIBUTION EQUIPMENT: NEC/CEC HAZARDOUS LOCATION PANELBOARDS

Illustrated Features

Two Door Design

Breaker compartment and junction compartment can be accessed independently of each other.

Tamper Proof Construction

Provisions for padlocking individual breakers in either ON or OFF position are provided on the front of the breaker compartment.

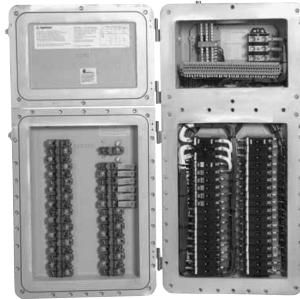

Flexibility in Breaker Selection

In addition to having 36 circuits available, 1-, 2- or 3-pole breakers may also be specified in any combination. Ground-Fault Circuit Interrupters may also be specified for any and all breaker positions, with test buttons located adjacent to the breaker operating handle.

Factory Sealed

Sealing cement seals and protects wiring where it passes from junction to circuit breaker compartment. Branch hubs do not require external seals to maintain hazardous location ratings (except Division 1, Group B and C ♦).

Corrosion-Resistant Housing

The junction and breaker housing are constructed of a rugged, one piece, two compartment integral casting of copperfree aluminum. Heavy duty stainless steel mounting brackets allow easy installation. The exterior and interior of the housing and doors have epoxy powder coat finish.

Watertight Gasketed Doors

Each door has an independent watertight gasket for NEMA 4 performance.



Improved Patented Actuator Handles

Rotary breaker handles provide dependable performance under heavy corrosion conditions. Handle also gives positive visual indication of breaker position. Improved spring loaded breaker actuators are also designed for corrosion resistance and are completely self-locating.

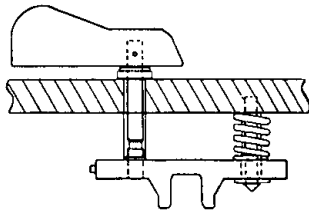

12, 24, or 36 Circuits

The EWP/D2P Panelboard lines are available in 12, 24 or 36 circuit versions.

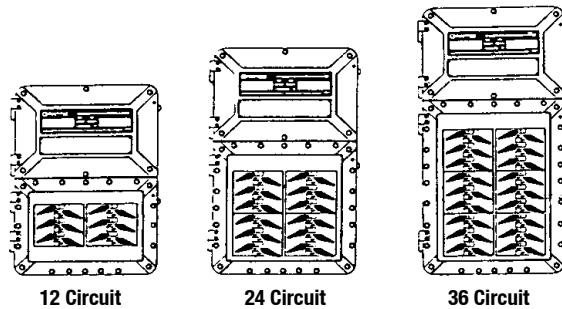

12 Circuit

24 Circuit

36 Circuit

Wire Management

Breaker wiring in the lower compartment is factory installed, saving installation time on the job site. Individual circuit connections are made to terminal blocks which are conveniently located in the front of the junction compartment. No. 10 wire is used throughout the panelboard breaker compartment. Wire bundles are crimped with a UL Listed method, and insulated for main lug assembly.

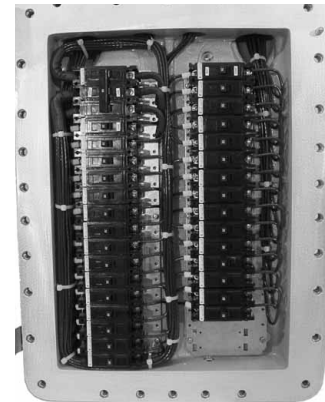

Removable Doors

Standard hinge position allows either door to be lifted off the enclosure to provide easy access to the interior.



Main Feed Conduit Openings

3" conduit openings at the top and bottom of the junction compartment permit either top or bottom feed entry. Threaded branch hubs are placed on all four sides for versatility and ease of installation.

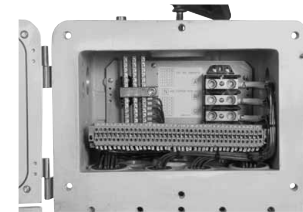

♦ For Groups B and C, all conduits must be sealed adjacent to enclosure.

D2P and EWP Factory Sealed Circuit Breaker Panelboards

Explosionproof, Dust-Ignitionproof, Watertight, Corrosion-Resistant

NEC:

Class I, Division 1 and 2, Groups B♦, C♦, D
 Class II, Division 1 and 2, Groups E, F, G
 Class III
 NEMA 3, 3R, 4, 4X, 5, 7BCD, 9EFG, 12

Ordering Instructions

- Step 1: Select Panel Type: D2P.
- Step 2: Select Wiring System Diagram Number (switching neutral, solid neutral or without neutral).
- Step 3: Select Panelboard Size: A (max. 12 1-pole spaces), B (max. 24 1-pole spaces) or C (max. 36 1-pole spaces).
- Step 4: Select Number of Breakers in Panel. If no Main Breaker required skip to number 6. If Main Breaker required, proceed to number 5.
- Step 5: Add MB (Main Breaker). The correct number of poles for the Main Breaker will be supplied automatically, depending on wiring system diagram selected.
- Step 6: Select Breakers as desired in panelboard. First number: quantity of breakers (1 15-60 Amp for 1-pole and 15-100 Amp for 2-pole, 3-pole); second number: ampere rating (continuous); and third number: number of poles. (Indicate only if different from wiring diagram selected). Each breaker pole takes one space. Select Breaker Type (see Options for details).
- Step 7: Repeat step 6 for Additional Breakers as desired.
- Step 8: Add dash preceding each suffix for other options/features (see Options).

NOTE: Main breakers use 2 or 3 branch circuit spaces.

Catalog Numbering Guide

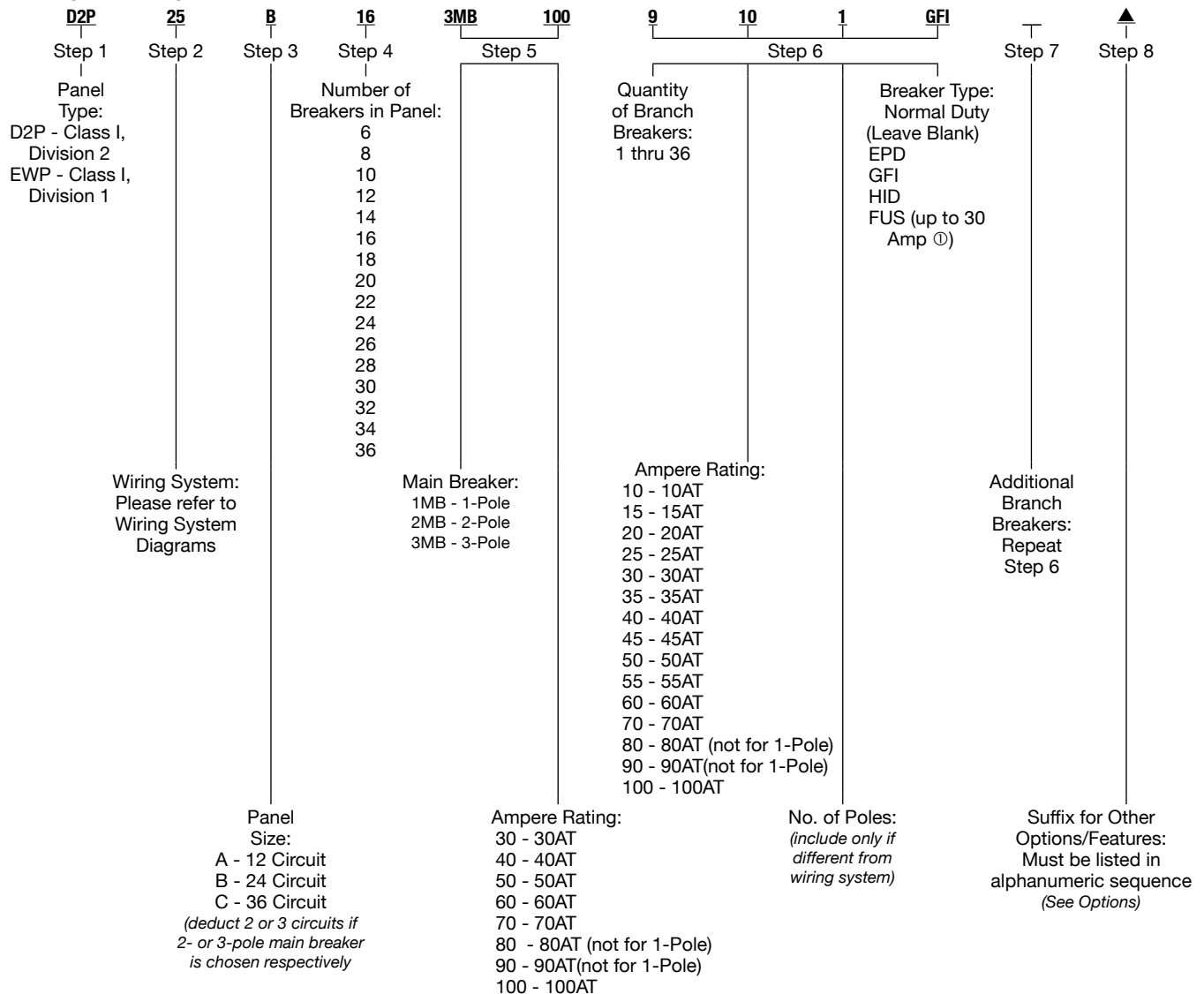

♦ For Groups B and C, all conduits must be sealed adjacent to enclosure.
 ▲ To complete the catalog number please add the appropriate suffix for other options/features. These suffixes can be found under Options.
 ① Fused terminal blocks available for branch circuits up to 30 Amps.



D2P and EWP Factory Sealed Circuit Breaker Panelboards

Explosionproof, Dust-Ignitionproof, Watertight, Corrosion-Resistant

NEC:
 Class I, Division 1 and 2, Groups B♦, C♦, D
 Class II, Division 1 and 2, Groups E, F, G
 Class III
 NEMA 3, 3R, 4, 4X, 5, 7BCD, 9EFG, 12

DISTRIBUTION EQUIPMENT: NEC/CEC HAZARDOUS LOCATION PANELBOARDS

EWP and D2P Series Breaker Voltage Specifications

For 22,000 AIC rated breakers contact your local representative.

Breaker Type	No. of Poles	Continuous Current Range (Amps)	Maximum Breaker Voltage Range	Interrupting Capacity Maximum Amps
QC	1	10-100	120/240	10.000
	2	10-100	120/240	10.000
	3	10-100	240	10.000
QPGF (GFI) or QPGFEP (EPD)	1	15-40	120	10.000
	2	15-50	120/240	10.000
QC (HID)	1	15-60	120/240	10.000
	2	15-60	120/240	10.000

Main Lug — Maximum 250 Amps — Cable Range: 250 MCM to 6

Number of Breakers	Panel Size	D2P Catalog Number ①		Number of Breakers	Panel Size	EWP Catalog Number ①	
		Wiring System Number 4 120/240 Vac	Wiring System Number 5 120/208 Vac			Wiring System Number 4 120/240 Vac	Wiring System Number 5 120/208 Vac
6	A	D2P4A6	D2P5A6	6	A	EWP4A6	EWP5A6
8	A	D2P4A8	D2P5A8	8	A	EWP4A8	EWP5A8
10	A	D2P4A10	D2P5A10	10	A	EWP4A10	EWP5A10
12	A	D2P4A12	D2P5A12	12	A	EWP4A12	EWP5A12
14	B	D2P4B14	D2P5B14	14	B	EWP4B14	EWP5B14
16	B	D2P4B16	D2P5B16	16	B	EWP4B16	EWP5B16
18	B	D2P4B18	D2P5B18	18	B	EWP4B18	EWP5B18
20	B	D2P4B20	D2P5B20	20	B	EWP4B20	EWP5B20
22	B	D2P4B22	D2P5B22	22	B	EWP4B22	EWP5B22
24	B	D2P4B24	D2P5B24	24	B	EWP4B24	EWP5B24
26	C	D2P4C26	D2P5C26	26	C	EWP4C26	EWP5C26
28	C	D2P4C28	D2P5C28	28	C	EWP4C28	EWP5C28
30	C	D2P4C30	D2P5C30	30	C	EWP4C30	EWP5C30
32	C	D2P4C32	D2P5C32	32	C	EWP4C32	EWP5C32
34	C	D2P4C34	D2P5C34	34	C	EWP4C34	EWP5C34
36	C	D2P4C36	D2P5C36	36	C	EWP4C36	EWP5C36

♦ For Groups B and C, all conduits must be sealed adjacent to enclosure.

① Catalog numbers shown are panelboards with 1-pole breakers for wiring systems 4 and 5. To order 1-, 2- and/or 3-pole breakers with different wiring systems, use Catalog Numbering Guide. Add ampere rating (continuous): 15 through 60 for 1-pole, and 15 through 100 for 2-pole and 3-pole.

D2P and EWP Factory Sealed Circuit Breaker Panelboards

Explosionproof, Dust-Ignitionproof, Watertight, Corrosion-Resistant

NEC:

Class I, Division 1 and 2, Groups B♦, C♦, D

Class II, Division 1 and 2, Groups E, F, G

Class III

NEMA 3, 3R, 4, 4X, 5, 7BCD, 9EFG, 12

Wiring System Diagrams

System No. 1	System No. 2	System No. 3	System No. 4	System No. 5
Mains—2-Wire Branches—2-Wire Breakers—2-Pole	Mains—3-Wire Branches—2-Wire Breakers—2-Pole	Mains—3-Wire Branches—3-Wire Breakers—2-Pole Solid Neutral	Mains—3-Wire Branches—2-Wire Breakers—1-Pole Solid Neutral	Mains—4-Wire, 3-Phase Branches—2-Wire, 1-Phase Breakers—1-Pole Solid Neutral
System No. 6	System No. 7	System No. 8	System No. 9	System No. 11
Mains—3-Wire Branches—3-Wire Breakers—3-Pole	Mains—2 Wire Branches—2-Wire Breakers—1-Pole Solid Neutral	Mains—4-Wire, 3-Phase Branches—3-Wire, 1-Phase Breakers—2-Pole Solid Neutral	Mains—3-Wire, 3-Phase Branches—2-Wire, 1-Phase Breakers—2-Pole	Mains—4-Wire, 3-Phase Branches—4-Wire, 3-Phase Breakers—3-Pole Solid Neutral
System No. 12	System No. 13	System No. 15	System No. 16	System No. 17
Mains—3-Wire, 3-Phase Branches—3-Wire, 3-Phase Breakers—3-Pole	Mains—4 Wire, 3-Phase Branches—2-Wire, 1-Phase Breakers—2-Pole	Mains—4-Wire, 3-Phase Branches—2-Wire, 1-Phase Breakers—1-Pole Solid Neutral	Mains—3-Wire Branches—2-Wire Breakers—1-Pole Solid Neutral	Mains—3-Wire Branches—3-Wire Breakers—3-Pole
System No. 22	System No. 24	System No. 25	System No. 28	System No. 29
Mains—3-Wire Branches—2-Wire Breakers—2-Pole	Mains—3 Wire Branches—2-Wire Breakers—1-Pole Solid Neutral	Mains—4-Wire, 3-Phase Branches—2-Wire, 1-Phase Breakers—1-Pole Solid Neutral	Mains—4-Wire, 3-Phase Branches—3-Wire, 1-Phase Breakers—2-Pole Solid Neutral	Mains—3-Wire, 3-Phase Branches—2-Wire, 1-Phase Breakers—2-Pole

♦ For Groups B and C, all conduits must be sealed adjacent to enclosure.

D2P and EWP Factory Sealed Circuit Breaker Panelboards

Explosionproof, Dust-Ignitionproof, Watertight, Corrosion-Resistant

D2P shown. D2P and EWP have same dimensions.

NEC:
 Class I, Division 1 and 2, Groups B♦, C♦, D
 Class II, Division 1 and 2, Groups E, F, G
 Class III
 NEMA 3, 3R, 4, 4X, 5, 7BCD, 9EFG, 12

DISTRIBUTION EQUIPMENT: NEC/CEC HAZARDOUS LOCATION PANELBOARDS

Dimensions in Millimeters (Inches)

Drilling Plans for Mounting Bolts

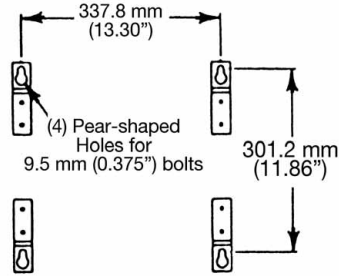

Top View

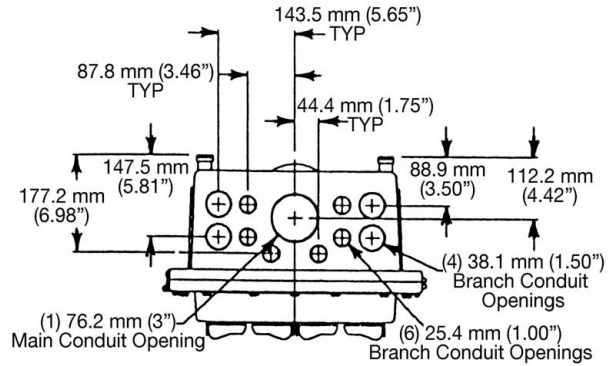

Side View

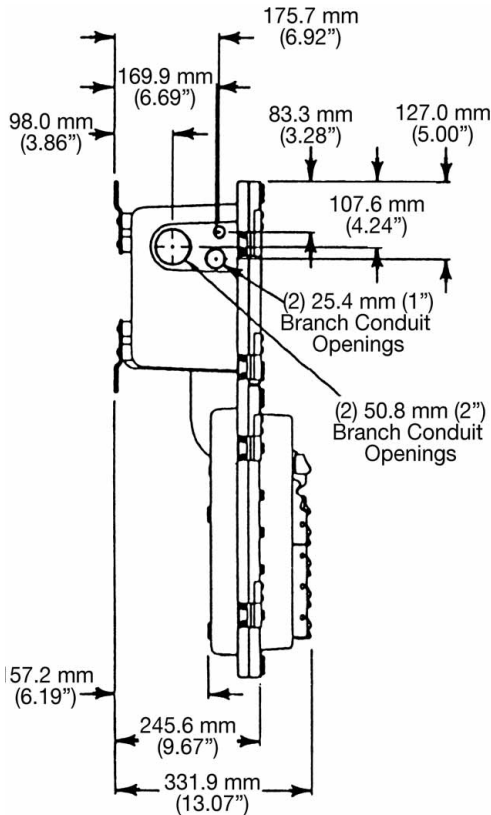

Front View

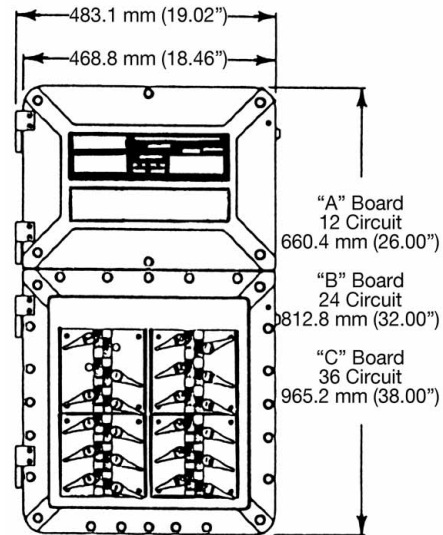

Bottom View

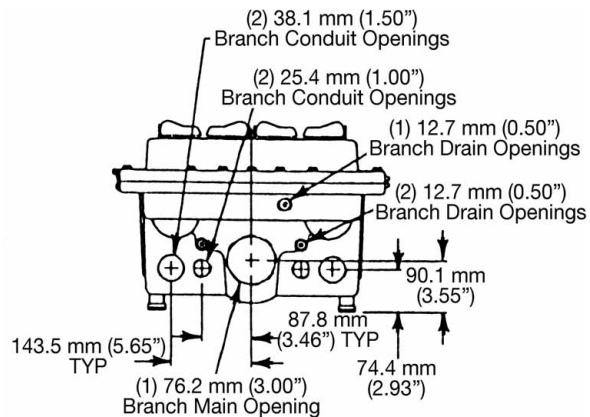

♦ For Groups B and C, all conduits must be sealed adjacent to enclosure.